

Operating Manual

Read instructions before operating

Model 21-080 Mini Gas Leak Detector

Model 21-080: 100 - 240 VAC, 50/60 Hz

June 2023

Rev. 0



**For new instrument right out of the box or one
that has not been used for quite some time:**

ALLOW UP TO 7 HOURS FOR FULL CHARGE.

FULL RUNTIME WILL RETURN AFTER

SEVERAL CHARGE/DISCHARGE CYCLES.

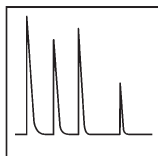

GOW-MAC[®]
INSTRUMENT CO.

Contents

1-0	Model 21-080 Mini Gas Leak Detector	5
2-0	Specifications	5
3-0	Instrument Operation	6
3-1	User Interface Display and Controls	6
3-2	Operation	8
4-0	Leak Checking Procedure.....	9
5-0	21-080 Parameter Descriptions	10
6-0	Troubleshooting.....	13
7-0	Charging the Cell / AC Operation.....	14
8-0	Sensitivity.....	14
9-0	Replacement Parts List.....	15

NOTICE The information in this document is subject to change without notice.

GOW-MAC® INSTRUMENT CO. MAKES NO WARRANTY OF ANY KIND WITH REGARD TO THIS MATERIAL, INCLUDING, BUT NOT LIMITED TO, THE IMPLIED WARRANTIES OF MERCHANTABILITY AND FITNESS FOR A PARTICULAR PURPOSE. GOW-MAC® Instrument Co. shall not be liable for errors contained herein or for incidental consequential damages in connection with the furnishing, performance, or use of this material.

This document contains proprietary information which is protected by copyright. All rights are reserved. No part of the document may be photographed, reproduced, or translated into another language without the prior written consent of GOW-MAC® Instrument Co.

The warranties made by GOW-MAC® Instrument Co. with respect to the product are voided if the product is not used and serviced in accordance with the instructions in this manual.

Please protect yourself and your employees by following these operating instructions. We encourage our customers to write or call for any additional information relative to the use or repair of this instrument.

Copyright© 2005-2023 by GOW-MAC® Instrument Co.

®GOW-MAC is a registered trademark of GOW-MAC Instrument Co., USA

1-0 Model 21-080 Mini Gas Leak Detector

- 1-1 The GOW-MAC® Model 21-080 Gas Leak Detector is supplied with a 3.5 ft. sampling probe and a power supply with 5 ft. cord.
- 1-2 The instrument contains a thermistor-type thermal conductivity detector (TCD), diaphragm pump, and a printed circuit board containing all microelectronic devices.
- 1-3 The Model 21-080 operates on 100-240 VAC, 50/60 Hz and three (3) internal rechargeable Ni-MH cells. An audible tone generator is incorporated with a speaker output. The audio signal permits the technician to test for leaks without visually scanning the meter.

2-0 Specifications

Detector	Thermal Conductivity Cell with Thermistors
Visual Readout	LCD display featuring adjustable brightness Peak hold with adjustable duration
Pump	Diaphragm type
Line Voltage	100-240 VAC, 50/60 Hz
Cell	Three (3) Rechargeable Ni-MH – 1.2 V, 1900 mAh, 1.9 Ah
Cell Life	Approximately 20 hours; Recharged to 90% of capacity in 5 hrs.; Low battery indicator; Very low battery shutdown
Ranges	Low: x1 High: x10 Adjustable sensitivity for low and high ranges Response time 3 seconds
Zero	Auto zero with drift elimination and manual override
Audio Signal	Audible Alarm with adjustable setpoint and volume
Dimensions	7.5" L x 4.1" W x 3.0" H (19.0 cm x 10.4 cm x 7.6 cm)
Weight	Instrument: 1.2 lbs (0.52 kg) Charger: 0.6 lbs (0.28 kg)
Features	Flash memory for saving settings Microprocessor controlled
Operating Temp. Range	70 °F ± 20 °F (21 °C ± 11 °C)
Accessories	Testing to a NIST-traceable standard



THE GOW-MAC GAS LEAK DETECTOR IS *NOT* DESIGNED TO BE USED TO DETERMINE LEAKS OF COMBUSTIBLE GASES. IT IS DESIGNED TO DETERMINE LOW LEVEL LEAKS OF ANY GAS HAVING A DIFFERENT THERMAL CONDUCTIVITY THAN AIR. UTILIZING THIS PROPERTY, IT IS THEREFORE NOT SPECIFIC TO ANY GAS OR VAPOR. A COMBUSTIBLE GAS LEAK DETECTOR SHOULD BE USED FOR THE DETERMINATION OF COMBUSTIBLE GAS LEAKS IN POSSIBLE HAZARDOUS CONDITIONS.

3-0 Instrument Operation

3-1 User Interface Display and Controls

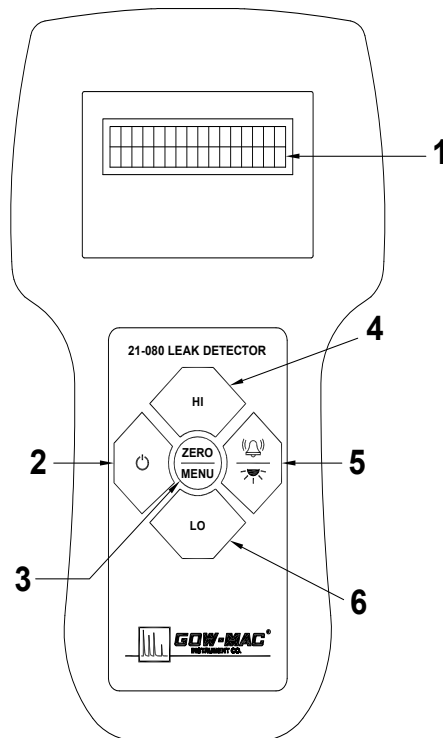

Figure 3-1

3-1-1 LCD Display, 16 segments per row, two rows, controllable backlight

The display is the visual instrument output and user interface when the control buttons are engaged. After power up and a 20 second warmup, the default display shows X1 for the low gain sensing range and BATT with 0 to 4 bars to indicate battery charge status. The bottom row shows "Sensing" indicating that the instrument is operating in leak detection mode. During the 20 second warmup period, all buttons including power are disabled.

3-1-2 Power Button

Press briefly (short press) to power on. Press and hold for 1 second (long press) to power off. Use the Power button when in the menu to scroll through instrument parameters.

3-1-3 ZERO/MENU Button

A short press of the ZERO/MENU button adjusts the output to zero which is neutral signal from the detector. The signal direction is either positive, indicated on the display as POS, or negative, indicated as NEG. The direction, POS or NEG, is a function of the thermal conductivity of the leak compared to ambient air or atmosphere. Gases, for example helium, with thermal conductivity greater than air indicate as NEG. Gases, for example argon, with thermal conductivity lower than air indicate as POS.

3-1-4 HI Button

Increase the instrument sensitivity or gain by a factor of 10. The range X10 is shown on the display. Also use this button to increase a parameter value when in the menu.

3-1-5 Alarm/Backlight Button

Press the alarm/backlight button briefly to select between audible alarm ON and OFF. Use a long press of the alarm/backlight button to select between display backlight ON and OFF. Backlight intensity is user-settable in the menu. Use the Alarm/Backlight button when in the menu to scroll through instrument parameters.

3-1-6 LO Button

Decrease the instrument sensitivity or gain by a factor of 10. The range X1 is shown on the display. Also use this button to decrease a parameter value when in the menu.

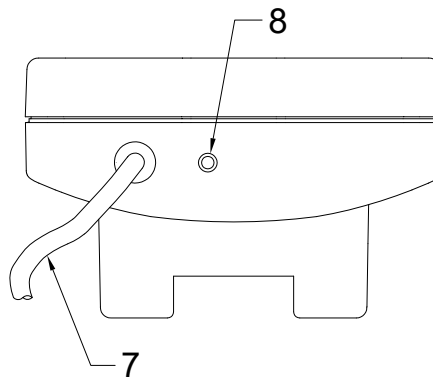

Figure 3-2

3-1-7 Sample Probe and Inlet Tubing

Wand with internal tubing through which the internal pump draws the gas sample. The pump is energized and therefore drawing sample all the time that the 21-080 power is on. Use care to prevent the probe inlet from getting submerged in water and to prevent dust ingress. The probe can be snapped into the clip on the side opposite the power jack to enable one-handed operation.

3-1-8 Reference Air Inlet

The hole next to the sample probe is connected to the detector. Ambient air that is drawn through the detector is the reference for the sample measurement. The leak magnitude signal is generated by the thermal conductivity difference between sample picked up by the probe and ambient air pulled in at the reference air inlet.

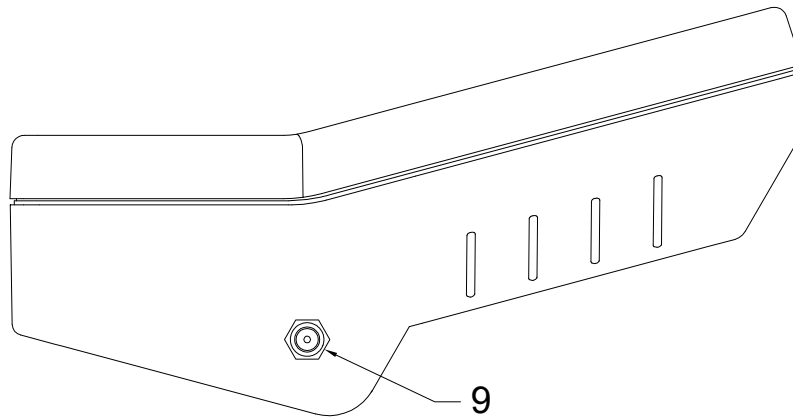

Figure 3-3

3-1-9 Power Adapter Receptacle

Power for battery charging and for plugged in operation is connected to the power adapter receptacle. Use only A/C power adapter/charger GOW-MAC part number 118-100 or the 21-080 can be damaged and its warranty voided.

3-2 Operation

3-2-1 Connect the power adapter plug to the receptacle on the side of the enclosure. Connect the power adapter to a 100 to 240 VAC outlet. Allow up to 5 hours to charge the internal battery.

3-2-2 Press the Power button. Short press switches power on and long press switches power off.

3-2-3 Select LO or HI sensitivity.

LO range = X 1

HI range = X 10

NOTE: "Zeroing" appears on the display after selection of HI or LO, after exiting the menu, and any time the MENU/ZERO button is briefly pressed. Zeroing indicates a 5 to 10-second period of zeroing the signal. Completion is indicated when "zeroing" is replaced by "sensing".

3-2-4 Signal zero can be done at any time by briefly pressing MENU/ZERO button (extended press of the MENU/ZERO button is the way to enter the 21-080 menu).

3-2-5 Activate the audible alarm to supplement the visual output on the display.

3-2-6 Areas to be tested must be free of oil, grease, paint, water, and other contaminants that might mask a leak or be drawn into the sampling probe.

3-2-7 To look for a leak, move the sample probe opening to the target area or fitting.

NOTE: to locate the smallest leaks on HI range, the user should wear a glove on the hand holding the probe to isolate the user from the probe inlet.

3-2-8 Leak indication. Segments on the bottom row of the display appear when a leak is detected. The number of segments from 1 to 16 illuminate in proportion to the intensity of the signal which is proportional to the concentration of the sampled gas.

4-0 Leak Checking Procedure



**EXTREME CARE SHOULD BE EXERCISED
WHEN THE PROBE IS USED AROUND
ELECTRICAL HEATERS, SWITCHES, ETC.**

- 4-1 Care must be exercised to avoid exhaling of breath near the probe or instrument housing itself. The carbon dioxide (CO₂) exhaled can be drawn into the sample probe or the reference air inlet of the leak detector and falsely indicate a leak.
- 4-2 If helium (He) is being checked, a leak indicates polarity NEG (negative). Most other gases or vapors indicate POS (positive polarity). Polarity is on a function of the sample (leak) gas's thermal conductivity relative to ambient air reference.
- 4-3 When checking for leaks, it is **IMPERATIVE** that fittings or suspected leak areas are **DRY**. If the area has previously been checked with a water based bubble type solution and **HAS NOT BEEN DRIED**, low readings, as well as possible detector contamination may occur. For example, the thermal conductivity of water vapor will counteract the signal from helium leaks. The net effect will be false low leak indication.



**DO NOT ALLOW MOISTURE TO BE DRAWN
INTO THE PROBE!**

- 4-4 Using the probe, carefully move the tip around and over suspected joints, seals, seams, or other areas where leaks occur. The probe must be moved slowly to detect small leaks.
- 4-5 A leak is indicated by illumination of display segments and by sound if the alarm is enabled. Remove the probe from the area, allow the segments to settle to zero (rezero if necessary), and return probe to the suspected location to verify the leak.
- 4-6 For more detailed information on leak detector sensitivity, refer Section 8-0 Sensitivity.

5-0 21-080 Parameter Descriptions

The 21-080 parameters are functions that can be changed in the menu.

21-080 Parameter	Function	Available range	Default setting
Alarm volume	Audible alarm sound level	0 – 100 %	50 %
Alarm type	Alarm enable and type of tone	Select constant tone, beeping tone, or alarm off	constant
Alarm set point	Set threshold for alarm sound	1 – 16 segments of the display	10
Pump speed	Air flow intake by the probe	0 – 100 %	50 %
Backlight	LCD display backlight brightness	0 – 100 %	50 %
LO range sensitivity	Adjust sensitivity within low range	0 – 100 %	50 %
HI range sensitivity	Adjust sensitivity within high range	0 – 100 %	50 %
Peak hold on-off	The high signal (maximum illuminated segments) of a transient leak is marked by * on the display	On or off	on
Peak hold delay	Time that the peak indicator * remains displayed	0 to 999 seconds	20 sec
Auto zero on-off	Continuous adjustment of long-term zeroing (while signal is below 3 bars)	On or off	on
Auto zero speed	Rate of continuous adjustment	0 – 100 %	50 %
Restore settings	Restore factory default settings Must select YES and confirm YES to restore.	Yes or no	no

Summary of 21-080 user-settable parameters

A long press of the ZERO/MENU button opens the menu of user-settable operating parameters. Leak detection output is disabled when in the menu. One must scroll through the 21-080 parameters described in Section 5 to make a change. Scroll using the Power button and the Alarm/Backlight buttons. When the parameter shows in the display, use the HI and LO buttons to change the value. The factory default settings can be restored with one of the menu options. A parameter setting change must be saved with a short press of the MENU/ZERO button or will not save. Exit menu with long press of the MENU/ZERO button. The 21-080 exits the menu automatically after about 1 minute of no activity in the menu. The 21-080 performs a signal zero automatically upon menu exit.

5-1 Alarm Volume

Sets the alarm sound level. The level increases with a higher % setting.

A	L	A	R	M	V	O	L	U	M	E				
0	5	0	%											

5-2 Alarm Type

Select either a constant tone or a beeping tone with frequency that changes with the leak size; faster for larger leak.

A	L	A	R	M	T	Y	P	E						
C	O	N	S	T	A	N	T							

5-3 Alarm Set Point

Set the threshold for alarm to sound as the leak size increases.

A	L	A	R	M	S	E	T	P	O	I	N	T		
0	1	0	S	E	G	M	E	N	T	S				

5-4 Pump Speed

The frequency of the pump diaphragm stroke is adjustable. This affects the air flow rate through the probe and detector. Higher speed causes a faster response time to a leak but decreases concentration of sampled gas..

P	U	M	P	S	P	E	E							
0	5	0	%											

5-5 Backlight

Adjust the intensity of the LCD display backlight. Higher backlight setting reduces time the instrument can run on battery between charges.

B	A	C	K	L	I	G	H	T						
0	5	0	%											

5-6 Range Sensitivity

HI range is 10 times more sensitive to leaks than LO range. Within each of LO and HI range, the sensitivity can be further adjusted. The tradeoff for increasing sensitivity is that the output becomes noisy and must be zeroed more frequently to be useful.

L	O	R	A	N	G	E	S	E	N	S	.		
0	5	0	%										
H	I	R	A	N	G	E	S	E	N	S	.		
0	5	0	%										

5-7 **Peak Hold On-Off**

The high point of a transient leak indication can be marked on the display with an asterisk * when peak hold ON is selected. The 21-080 is not a quantitative device, however leak peak levels indicate relative concentrations of the target leaking gas.

P	E	A	K	H	O	L	D	O	N	~	O	F	F
O	N												

5-8 **Peak Hold Delay**

Set the duration that the peak hold marker (*) remains on the display. A peak hold marker is overwritten if the next leak is detected before the end of the hold period.

P	E	A	K	H	O	L	D	D	E	L	A	Y	
0	2	0	S	E	C	O	N	D	S				

5-9 **Auto Zero On-Off**

The 21-080 is in a “zero” state when no display segments are lit; when the detector output equals a reference output that is saved in the firmware. The detector output drifts due to environmental conditions especially temperature, drafts, and ambient air (the reference part of the detector output). As the detector output drifts, the saved reference must be made to match the detector output to keep the signal zeroed. This forced matching happens when Auto Zero is ON.

A	U	T	O	Z	E	R	O	O	N	~	O	F	F
O	N												

5-10 **Auto Zero Speed**

Auto Zero Speed is active only when Auto Zero is ON. The zeroing must be fast enough to keep the display segments from lighting, yet not too fast to affect leak detection. That balance is controlled by Auto Zero Speed. The Auto Zero Speed is the speed at which the zero reference (saved in firmware) is made to match the detector output.

The Auto Zero only runs when there are less than 3 lit segments.

If no segments are lit for 10 consecutive 100 millisecond periods, then the zero reference (saved in firmware) is made to match the detector output.

If 1 or 2 segments are active, a counter is incremented or decremented (depending on whether a pos or neg signal) every 100 milliseconds. If the counter goes above the threshold value of Auto Zero Speed, then the zero reference is incremented towards the detector value. This continually repeats until the zero reference equals the detector output.

A	U	T	O	Z	E	R	O	S	P	E	E	D	
0	5	0	%										

5-11 Restore Settings

The settings for all menu parameters can be reset to factory default values by selecting YES on the RESTORE SETTINGS menu page. The user will be prompted to confirm change to default settings.

R	E	S	T	O	R	E	S	E	T	T	I	N	G	S								
N	O																					

5-12 Software Revision

The last page of the menu scroll shows the installed software revision.

S	O	F	T	W	A	R	E	R	E	V	.											
X	.	Y	Z																			

6-0 Troubleshooting



REMOVE AC POWER ADAPTOR FROM OUTLET

6-1 Instrument will not zero

6-1-1 Check for clogged probe or obstructed reference inlet.

6-1-2 Check instrument settings. Reset to factory defaults if necessary.

6-2 Response time has increased

6-2-1 Diaphragm on pump is leaking. Replace diaphragm.

6-2-2 Sample line (probe) has become punctured. Replace probe assembly.

6-3 Sensitivity has decreased

6-3-1 Sample line (probe) has been punctured. Replace probe assembly.

6-3-2 Probe assembly leaking. Replace probe assembly.

6-3-3 Pump operating improperly. Replace pump.

6-3-4 Check instrument settings. Reset to factory defaults if necessary.

6-4 If repair service is needed, contact our repair department at: repairs@gow-mac.com or scan the Q code for our website and click on Services Tab and the Repair Tab for further instructions.



7-0 Charging the Cell / AC Operation

- 7-1 The Model 21-080 Mini Gas Leak Detector operates off an internal rechargeable cell. When the cell is discharged, the instrument may continue to be run while the light is flashing, however the unit will shut down automatically when the cell is discharged to a point that it will no longer operate correctly. When using the supplied +9 Volt AC adaptor, the instrument will operate and slowly recharge the cell. To fully charge the cell, switch the instrument power "off" and allow to charge for a approximately 6 to 7 hours.

8-0 Sensitivity

The 21-080 leak detector user is encouraged to read ASTM standard ASTM E2024/ E2024M-11 Standard Practice for Atmospheric Leaks Using a Thermal Conductivity Leak Detector.

- 8-1 Recommended technique for sampling with a leak detector probe. The probe tip shall be held not more than 1 mm (0.04 inch) from the test surface and moved not faster than 20 mm/sec (0.8 inch/sec). To obtain the best approximate leak measurement, the sample gas (the leak), reference gas (ambient atmosphere) scanning rate and distance should be identical to the conditions for calibrating the leak detector, explained as follows.
- 8-2 Calibration of the GOW-MAC 21-080 leak detector. Use a calibrated leak that can be filled with the same gas as the leak. GOW-MAC verifies the sensitivity of its leak detectors by testing with a NIST-traceable calibrated helium leak. This is a service for new and used instruments. The certified 21-080 sensitivity is 10% of full-scale meter deflection on HI range with sensitivity set to 50%.
- 8-3 Minimum detectable levels are determined by the thermal conductivity difference between the reference and sample gases. Reference gas is the ambient atmosphere, which is normally air. Sample gas is the leak picked up by the probe. Both are drawn across thermistors in the detector. The gas flow cools the thermistors at different rates which changes their respective resistances. The resistance change is processed into the leak indication segments on the display. Minimum detectable leaks for a few gases are generally according to this table.

Sensitivity Chart		
Minimum leak rate required to produce 10% deflection of full scale		
Helium (He)	1.0×10^{-5} cc/sec	0.012 cu ft/yr
Argon (Ar)	1.0×10^{-4} cc/sec	0.110 cu ft/yr
Carbon Dioxide (CO)	1.0×10^{-4} cc/sec	0.123 cu ft/yr
Helium (He)	1.0×10^{-4} cc/sec	0.123 cu ft/yr

9-0 Replacement Parts List

Part No.	Description
021-5-SS-1	Thermal conductivity detector
021-9-1	Probe assembly, mini leak detector, complete
133-152	Pump, vacuum micro, 3 V dc
119-126	Cell, 1.2 V / 1.9 Ah, nickel metal hydride, rechargeable, 3 cells per instrument
118-100	A/C power adapter/charger, 100 to 240 VAC input

Warranty

ALL INSTRUMENTS SOLD BY GOW-MAC® INSTRUMENT CO. ARE WARRANTED FOR A PERIOD OF ONE YEAR AGAINST DEFECTS IN MATERIALS AND WORKMANSHIP. THE TERMS OF THIS WARRANTY ARE AS FOLLOWS:

1. The warranty period begins with the shipping date of the equipment to the original purchaser.
2. Certain parts such as batteries, fuses, glass accessories, septa, columns, etc., are expendable in normal use, and their service life is unpredictable. Such items are not covered by this warranty.
3. Filaments of thermal conductivity detectors are not covered by this warranty.
4. Hydrogen Palladium Tubes are not covered by this warranty.
5. All requests for service or repair under this warranty must be received within the warranty period by GOW-MAC® or its authorized representative. All repairs are made at GOW-MAC plants or at the office of authorized representatives.
6. All repairs, adjustments, and other services under this warranty shall be performed free of charge to the purchaser. However, warranty service and repairs shall be limited to equipment malfunctions which, in the opinion of GOW-MAC®, are due or traceable to defects in original materials or workmanship. Instrument malfunctions caused by abuse or neglect of the equipment are expressly not covered by this warranty.
7. Instrument parts which have been repaired or replaced during the warranty period are themselves warranted only for the remaining unexpired portion of the original one-year warranty.
8. Repairs, adjustments, and service performed after expiration of the one-year warranty period shall be charged to the purchaser at the then current prices for parts, labor, and transportation.
9. This warranty attaches to the equipment itself and is not limited to the original purchaser. Unexpired portions of the warranty are thus transferable to subsequent owners.
10. GOW-MAC® expressly disclaims any liability to users of its products for consequential damages of any kind arising out of or connected with the use of its products.
11. Except as stated in Sections 1 through 8 above, GOW-MAC® makes no warranty, expressed or implied (either in fact or by operation of law), statutory or otherwise; and, except as stated in Sections 1 through 8 above, GOW-MAC® shall have no liability under any warranty, expressed or implied (either in fact or by operation of law), statutory or otherwise.
12. Statements made by any person, including representatives of GOW-MAC® which are inconsistent or in conflict with the terms of this warranty shall not be binding upon GOW-MAC® unless reduced to writing and approved by an officer of the Company.
13. This warranty shall be governed by the laws of the Commonwealth of Pennsylvania.

7/5/23
kj

Health and Safety Declaration for the Return of GOW-MAC Instrument Co. Equipment

In order to protect our employees from exposure to various hazards, the following statements and/or questions **MUST** be answered by you. Fill out this document in its entirety and either fax or e-mail it to GOW-MAC Instrument Co., Attn: Repair Dept, **BEFORE** returning the product.

The instrument/part being returned **will not** be accepted into GOW-MAC's facility until we receive this completed document, along with a **PO or Credit Card**. Once approved for return by our Chemical Safety Officer, a **Return Materials Authorization (RMA) number** and shipping instructions will be issued. *All applicable regulations should be followed when returning instrumentation, and/or parts.*

Customer to Record the Following:

Model # / Part # _____
 Serial #: _____
 Service Technician spoken to: _____
 Today's Date: _____

IF THIS FORM IS NOT APPROVED BY OUR CHEMICAL SAFETY OFFICER, THE INSTRUMENT/PART WILL NOT BE PERMITTED INTO OUR FACILITY FOR SERVICING!

- A) Brief explanation of issue: _____
- B) Briefly list the application(s) for which the instrument/part was used, as well as any and all chemicals, gases, and/or materials analyzed and their concentrations. **(Must be filled in):** _____
- C) Is there the possibility of internal or external contamination on or in this instrument/part?
 Yes – see below No – proceed to D.

Please check the appropriate box.

- Chemicals or Substances That Are Hazardous to Health
- Blood, Body Fluids, (e.g. Urine, Secretions), Pathological Specimens
- Regulated Medical Wastes
- Infectious Substances or other Bio-Agents (e.g. Protein, Enzymes, Antibodies)
- Radioactive Isotopes used in the area. Detail type (ECD, Isotopic Labels, etc) and Activity in Micro Curies
- Biodegradable Material That Could Become Hazardous
- Other Hazards _____

If any of the above boxes are checked the following statements and/or questions must be answered.

1. Specifically describe where (on or in) the instrument/part there could be any residual contamination (for example: blood spill on the surface). _____
 2. Provide details of these hazards. Include names, Material Safety Data Sheets (MSDS), and concentration of contaminants, where possible. _____
 3. Describe the method of decontamination used. Attach Procedure. _____
- D) I declare that the above information is true and complete to the best of my knowledge. I acknowledge that any inconsistencies between the condition of the instrument and the statements made on this form will delay the repair process.

Authorized signature _____ Date: _____

Name (Printed) _____ Phone number: _____

Company name: _____ Fax number: _____

Shipping address: _____

City: _____ State/Country: _____ Zip: _____

E-mail address: _____

BEFORE item can be shipped, fax completed form to: (610) 954-0599 or e-mail it to: repairs@gow-mac.com

For GOW-MAC Use Only:

Signed: _____ Date ____/____/____

- Passed** Safety Inspection. **OK** to proceed to Repair Dept.
- Failed safety** Inspection. **DO NOT** proceed to Repair Dept.

Chemical Safety Officer

RMA No: _____

Comments: () None
 () On Back >>>>



REP-005
 Health-Safety Declaration Doc – ONLINE
 Rev.7 1/28/2022, kj