

Operating Manual

Series AR710 & AR720 High Frequency Argon Discharge Detector Gas Chromatographs

AR710:..... 110 V, 60 Hz (Single Column)
AR712:..... 230 V, 50 Hz (Single Column)

AR720:..... 110 V, 60 Hz (Dual Column)
AR722:..... 230 V, 50 Hz (Dual Column)

July 2023
Rev. 9

**READ INSTRUCTIONS
BEFORE OPERATING**



Contents

GENERAL PRECAUTIONS FOR HANDLING AND STORING HIGH PRESSURE GAS CYLINDERS	9
1 Introduction	11
2 Safety	13
3 Specifications.....	15
4 Installation	17
5 Operating Controls	23
6 Operation	27
7 Application Information.....	31
8 Maintenance & Servicing	33
9 Replacement Parts.....	35
10 Drawings & Schematics	37

DISCLAIMERS

The information in this document is subject to change without notice. This manual could include technical inaccuracies or typographical errors. Changes are made periodically to the information herein; these changes will be incorporated in subsequent revisions of the manual. GOW-MAC® Instrument Co. reserves the right to make improvements and/or changes to the product(s) and/or programs described in this manual at any time and without notice.

All information referred to and/or included in this report is current as of the original issue date of this manual. GOW-MAC® Instrument Co. makes no warranty or representation with respect to the accuracy of the information or with respect to the suitability of the use of such information outside GOW-MAC® Instrument Co., nor does GOW-MAC® Instrument Co. assume responsibility for any injury or damage which may result, directly or indirectly, from the use of such information.

This document contains proprietary information which is protected by copyright. All rights are reserved. No part of the document may be photographed, reproduced, or translated into another language without the prior written consent of GOW-MAC® Instrument Co.

The warranties made by GOW-MAC® Instrument Co. with respect to the product are voided if the product is not used and serviced in accordance with the instructions in this manual.

Please protect yourself and your employees by following these operating instructions. We encourage our customers to write or call for any additional information relative to the use or repair of this instrument.

TRADEMARK AND PATENT INFORMATION

®GOW-MAC is a registered trademark of GOW-MAC Instrument Co. in the United States and other countries. (Reg. U.S. Pat. & T.M. office)

Other trademarks used herein are trademarks or registered trademarks of their respective owners.

Copyright© 2009 - 2013 by GOW-MAC® Instrument Co.

TERMS AND CONDITIONS OF SALE

WARRANTIES SERIES AR710 AND AR720 ANALYZERS SOLD BY GOW-MAC® INSTRUMENT CO. IS WARRANTED FOR A PERIOD OF ONE YEAR AGAINST DEFECTS IN MATERIALS AND WORKMANSHIP. THE TERMS OF THIS WARRANTY ARE AS FOLLOWS:

1. The warranty period begins with the shipping date of the equipment to the original purchaser.
2. Certain parts such as batteries, fuses, glass accessories, septa, columns, etc., are expendable in normal use, and their service life is unpredictable. Such items are not covered by this warranty.
3. Filaments of thermal conductivity detectors are not covered by this warranty.
4. Hydrogen Palladium Tubes are not covered by this warranty.
5. All requests for service or repair under this warranty must be received within the warranty period by GOW-MAC® or its authorized representative. All repairs are made at GOW-MAC plants or at the office of authorized representatives.
6. All repairs, adjustments, and other services under this warranty shall be performed free of charge to the purchaser. However, warranty service and repairs shall be limited to equipment malfunctions which, in the opinion of GOW-MAC®, are due or traceable to defects in original materials or workmanship. Instrument malfunctions caused by abuse or neglect of the equipment are expressly not covered by this warranty.
7. Instrument parts which have been repaired or replaced during the warranty period are themselves warranted only for the remaining unexpired portion of the original one-year warranty.
8. Repairs, adjustments, and service performed after expiration of the one-year warranty period shall be charged to the purchaser at the then current prices for parts, labor, and transportation.
9. This warranty attaches to the equipment itself and is not limited to the original purchaser. Unexpired portions of the warranty are thus transferable to subsequent owners.
10. GOW-MAC® expressly disclaims any liability to users of its products for consequential damages of any kind arising out of or connected with the use of its products.
11. Except as stated in Sections 1 through 8 above, GOW-MAC® makes no warranty, expressed or implied (either in fact or by operation of law), statutory or otherwise; and, except as stated in Sections 1 through 8 above, GOW-MAC® shall have no liability under any warranty, expressed or implied (either in fact or by operation of law), statutory or otherwise.
12. Statements made by any person, including representatives of GOW-MAC® which are inconsistent or in conflict with the terms of this warranty shall not be binding upon GOW-MAC® unless reduced to writing and approved by an officer of the Company.
13. This warranty shall be governed by the laws of the Commonwealth of Pennsylvania.

LIABILITY Buyer assumes all responsibility for warning and protecting its employees and independent contractors with respect to all hazards to persons and property in any way connected with the Equipment and the use thereof. Seller's liability for any claim of any kind hereunder, whether or not based on contract, tort (including negligence), strict liability, warranty, or any other grounds, shall not exceed the purchase price of the Equipment or the portion of the purchase price attributable to any part or parts of the Equipment in respect to which such claim is made. Seller shall not be liable for any special, indirect, incidental, or consequential damages. Without limiting the generality of the foregoing, Seller shall have no liability with respect to the results obtained by use of the Equipment, whether in terms of product condition, operating cost, general effectiveness, success or failure, or regardless of any statement made in any written proposal submitted by Seller. It is expressly understood that any technical advice furnished by Seller with reference to the Equipment is given gratis and Seller assumes no obligation or liability for the advice given or results obtained, all such advice being given and accepted at Buyer's risk. Each party hereby agrees to indemnify and hold the other party harmless from any actions, lawsuits, demands, claims, losses, expenses, costs, including but not limited to legal fees, and damages arising from the injury, illness or death of the indemnifying party's employees in any way related to the Equipment, whether or not such injury, illness, or death is claimed to have been caused by, resulted from, or was in any way connected with the negligence of the party to be indemnified.

PROPRIETARY INFORMATION Buyer agrees to maintain all proprietary information disclosed by Seller, including such proprietary information obtainable upon examination of the Equipment, in confidence and to refrain from any disclosure thereof to any third party (including any affiliate of Buyer), for any purpose, without the prior written consent of Seller. Buyer agrees to use said proprietary information solely for purposes of maintaining and operating the Equipment, and to refrain from any use thereof to design, construct, have constructed and/or operate any duplication or modification of the Equipment, or from any other use thereof, without the prior written consent of Seller.

IMPORTANT INFORMATION

THIS MANUAL MUST BE CAREFULLY READ BY ALL INDIVIDUALS WHO HAVE OR WILL HAVE THE RESPONSIBILITY FOR INSTALLING, USING, OR SERVICING THE PRODUCT.

Like any piece of complex equipment, the Series AR710 or AR720 HFAD Gas Chromatograph will perform as designed only if it is installed, used and serviced in accordance with the manufacturer's instructions. OTHERWISE INSTRUMENT COULD FAIL TO PERFORM AS DESIGNED AND PERSONS WHO RELY ON THIS PRODUCT FOR THEIR SAFETY COULD SUSTAIN SEVERE BODILY INJURY OR DEATH.

Dangers, Warnings, Cautions, and Notes

Dangers, Warnings, Cautions, and Notes appear throughout this manual. A sample of each statement appears below. Within each sample, a definition of the statement type and its purpose is given.



DANGERS alert you to an immediate hazard that causes serious injury or death and requires special precautions to be taken.



WARNINGS alert you to a potential hazard that causes serious injury or death ***under certain conditions.***



CAUTIONS alert you to a non-immediate or potential hazard or an unsafe practice that presents a minor threat of personal injury or damage to equipment, data, or processes.



NOTE

NOTES emphasize or remind you of an important piece of information.

Please protect yourself and your employees by following these operating instructions. We encourage our customers to write or call for any additional information relative to the use or repair of this instrument.

Technical Support

GOW-MAC Instrument Co.
277 Brodhead Road
Bethlehem, PA 18017 U.S.A.

Phone: (610) 954-9000
Hours: 8:00 am - 4:30 pm EST, Monday - Friday

Fax: (610) 954-0599

E-mail: sales@gow-mac.com



GENERAL PRECAUTIONS FOR HANDLING AND STORING HIGH PRESSURE GAS CYLINDERS



Compressed gases have properties that can cause serious accidents, injuries, and even death if proper precautions and safety practices are not followed. Therefore, during handling and use of these gases, be certain to use applicable safety precautions described by your local compressed gas supplier, the Compressed Gas Association, and/or O.S.H.A. regulations.

1. Read the label on all cylinders **BEFORE** using to identify the cylinder contents. If the label is illegible, return the cylinder to the supplier. **DO NOT ASSUME THE CONTENTS.**
2. Secure cylinders in storage and in use to an immovable structure to prevent accidental falling or movement. Read the relevant safety codes.
3. Store or move cylinders **ONLY** in the vertical position. **DO NOT** move or transport cylinders with regulators attached.
4. Store cylinders in a well ventilated area away from heat or ignition sources.
5. When installing tubing, provide **ONLY** approved, adequate pressure reducing regulators and pressure relief devices to prevent over-pressurizing of tubing and equipment.
6. Never drop cylinders or permit them to strike each other violently.
7. Cylinders may be stored in the open but, in such cases, should be protected against extremes of weather and from damp ground (to prevent rusting). In areas where extreme temperatures are prevalent, store cylinders in the shade.
8. The valve protection cap should be left on each cylinder until cylinder has been secured against a wall or bench, or placed in a cylinder stand and is ready for use.
9. Avoid dragging, rolling or sliding cylinders even for a short distance. Move cylinders by using a suitable hand truck.
10. Never tamper with safety devices in valves or cylinders.
11. Do not store full and empty cylinders together. Serious suck-back can occur when an empty cylinder is attached to a pressurized system.
12. No part of a cylinder should be subjected to a temperature higher than 52 °C (125 °F). Do not permit flame to come in contact with any part of a compressed gas cylinder.

Introduction

The Series AR710 and AR720 Analyzers are equipped with a High Frequency Argon Discharge Detector (HFADD). This detector is ideally suited for the analysis of impurities in bulk argon gas.

1.1 Principle of the Analyzer

A fixed volume of sample is injected into an argon stream of carrier gas and it passes through a column packed with a stationary phase. The components of the sample separate on the column and are monitored by a detector. The detector output is monitored by a chart recorder, a computing integrator, or a computer data system. The output device gives a series of peaks. Each peak relates to one of the separated components of the mixture. Each peak is integrated by the data system, with the corresponding areas being proportional to the concentration of each component in the sample.

1.2 High Frequency Argon Discharge Detector

The gas passing through the detector is subjected to a high electromagnetic field, hereby causing the gas to resonate. The resulting luminance is monitored by a light dependant resistor (LDR). As the sample component elutes from the column the light intensity is altered by the non-argon components. The output from the LDR is converted to a mV signal and is measured by the output device.

2 Safety

This section is designed to bring special attention to specific areas or practices that may pose particular hazards to personnel and/or equipment.

IT IS IN THE OPERATOR'S BEST INTEREST TO READ THIS SECTION TO ENSURE THE SAFE OPERATION OF THE INSTRUMENT.

2.1 General

- A. The Series AR710 or AR720 Gas Chromatograph should be installed, operated and maintained in strict accordance with its labels, cautions, warnings, instructions, and within the limitations stated.
- B. Perform periodic leak checks at all fitting areas.
- C. Store organic solvents away from the analyzer in fireproof, vented, labelled cabinets.
- D. **DO NOT** allow flammable and/or toxic wastes to accumulate.
- E. Keep combustibles away from gas cylinders and eliminate ignition sources.
- F. **DO NOT** place papers, charts, samples, etc. on top of the analyzer.
- G. It is important to maintain adequate ventilation and dispose of waste properly.

2.2 Replacement Parts

Use genuine GOW-MAC replacement parts when performing any maintenance procedures provided in this manual. Failure to do so may seriously impair instrument performance. Repair or alteration of the Series AR710 or AR720 Gas Chromatograph beyond the scope of these instructions or by anyone other than GOW-MAC or a GOW-MAC representative could cause the product to fail to perform as designed, and persons who rely on this product for their safety could sustain severe bodily injury or death.

2.3 Ultra Violet Ray Hazards



The Ultraviolet Ray (UV) is harmful to the naked eye. When checking the system it is important that the discharge is viewed using a UV absorbing filter such as borosilicate glass or polystyrene.

2.4 Burn Hazards



The detector, column and column oven may reach very high temperatures and remain **HOT** for several hours after the instrument has been shutdown. To prevent painful burns resulting from contact with hot surfaces, the operator should wear protective gloves when touching these surfaces.

2.5 Electrical Hazards



- A. This instrument employs voltages that are very dangerous. **EXTREME CAUTION MUST BE EXERCISED WHEN WORKING WITH THIS INSTRUMENT.** Disconnect the instrument from all power sources before removing front, side or back panels and exposing potentially dangerous voltages.
- B. **DO NOT** handle exposed voltage termination's until the load and/or supply has been discharged (grounded). An unloaded supply may take up to 15 seconds to fully discharge.
- C. Make sure that the actual line voltage is the correct value for the instrument.
- E. **DO NOT** overload the AC outlet with other electrical equipment.
- F. Adhere to the color coding descriptions when making electrical connections.
- G. Repair or replace faulty or frayed wiring **IMMEDIATELY** should it occur.

2.6 Compressed Gas Cylinders



- A. Compressed gas cylinders are potential sources of serious accidents, injuries and even death if proper precautions and safety practices are not followed. Therefore, during handling and use of compressed gas cylinders, be certain to use applicable safety precautions described by your local compressed gas supplier, the Compressed Gas Association, and/or O.S.H.A. regulations.
- B. Read the label on all cylinders **BEFORE** using to identify the cylinder contents. If the label is illegible, return the cylinder to the supplier. **NEVER ASSUME THE CONTENTS OF A GAS CYLINDER.**
- C. **ALL** gas cylinders in use and in storage **MUST** be secured to a stationary structure to prevent accidental falling or movement.
- D. Store or move cylinders only in the **VERTICAL** position.
- E. Store cylinders in a well ventilated area away from heat or ignition sources.
- F. When installing tubing, provide only approved, adequate pressure reducing regulators and pressure relief devices to prevent overpressure on tubing and equipment.

Specifications

3.1 Sections

The Series AR710 or AR720 Gas Chromatograph is made up of two modules:

A. Detector Module

Part No. 157-104 (115 V)

Part No. 157-104-1 (230 V)

B. Oven Module

Single Column Unit: Part No. 158-104 (115 V) or 158-104-1 (230 V)

Dual Column Unit: Part No. 158-104-2 (115 V) or 158-104-3(230 V)

3.2 Detector

Type: Discharge luminosity

Sensitivity:

(ppb)	H ₂	O ₂	N ₂	CH ₄	CO	CO ₂
(a)	< 15	< 75	< 100	< 30	< 200	-----
(b)	< 15	< 75	< 100	< 30	<200	< 100

Option (b) results are achieved through the use of an additional Gas Sample Valve

Temperature Range: Ambient to 400 °C

Linearity: >10³

3.3 Gas Flow

Carrier Gas: Ultra High Purity (UHP) N6.0 Argon (Ar) with UHP 2-stage argon pressure regulator* for flow control through columns

***note:** if the carrier gas is not as pure as the sample gas, reverse peaks can occur for gases which are in lower concentration in the sample gas.



ARGON CARRIER GAS *MUST* BE GRADE 6 (N6.0) OR BETTER. ARGON GRADES LOWER THAN GRADE 6 MUST BE PASSED THROUGH AN ARGON GAS PURIFIER. FAILURE TO COMPLY WITH THIS WILL CANCEL THE WARRANTY OF THE SYSTEM.

3.4 High Voltage Power Supply

Output: Continuous adjustment by means of an external potentiometer.

3.5 Output Signal: 0 - 100 mV

3.6 Operating Temperature: 50 °F to 104 °F (10°C to 40 °C)

3.7 Column Oven

Temperature Range: ambient +4 °C

Temperature readout: Dual 4-digit, 7-segment LED display(s)

Temperature Control:

Accuracy: ± 1% of rates, ± 1% of setting

Stability: < ± 0.05 °C/hr, 30 minute warm-up

3.8 Connections

Inlets: 1/8-inch VCR Swagelok®

Outlets: 1/8-inch Swagelok®

3.9 Dimensions (overall)

Height: 14" (356 mm)

Width: 19" (483 mm)

Depth: 18" (457 mm)

Dimensions (per section)

Height: 7" (178 mm)

Width: 19" (483 mm)

Depth: 18" (457 mm)

3.10 Weight

A. Detector Module: 30 lbs. (13.5 kg)

B. Oven Module: 35 lbs. (15.75 kg)

3.11 Power Requirements

Series AR710 1100 Watts, 110/115 V ac, 60 Hz

Series AR720 1100 Watts, 110/115 V ac, 60 Hz

Series AR712 1100 Watts, 220/240 V ac, 50 Hz

Series AR722 1100 Watts, 220/240 V ac, 50 Hz

Installation

It is EXTREMELY IMPORTANT that the operator becomes familiar with this section BEFORE proceeding with the installation of this instrument.

4.1 Additional Equipment Required

- A. High capacity carrier gas purifier capable of removing H₂, O₂, N₂, CH₄, CO and CO₂.
- B. Flow meter.
- C. Ultra high purity Argon (Ar). Carrier gas cylinder should be equipped with a **NEW** ultra high purity regulator terminating in a 1/4-inch VCR fitting.
- D. Potentiometric recorder with 1 mV or 10 mV span and < 1 sec. response. A computing integrator or data handling computer software may also be used.
- E. AC Power source:

Series AR710	1100 Watts, 110/150 V, 60 Hz
Series AR720	1100 Watts, 110/150 V, 60 Hz
Series AR712	1100 Watts, 220/240 V, 50 Hz
Series AR722	1100 Watts, 220/240 V, 50 Hz



Operating instructions for both models are the same, except for line voltage requirements. To prevent damage to the instrument, Ensure that the AC electrical outlet is the correct voltage before plugging the Instrument to this Outlet.



DO NOT plug the instrument to the power source at this time.

4.2 Unpacking & Inspection

- A. When unpacking the instrument, check it carefully for evidence of shipping damage **or** rough handling. Check to ensure that all components ordered have either been supplied or back ordered. Notify the Company of any discrepancies. The packing box should be retained for use if the instrument needs to be returned to the factory for repair or modification, within the warranty period. GOW-MAC *does not* supply field service. ALL repairs are made in Bethlehem, PA or by an authorized GOW-MAC representative.
- B. Remove all plastic and/or paper shipping caps and restraints before operating.

- C. Fill out and mail the yellow WARRANTY-REGISTRATION CARD (included with this manual) to ensure that the warranty will be validated and that you will be kept informed of any improvements or other items of interest.

4.3 Location

- A. The AR710 Series Gas Chromatographs should be placed in a location that is secure, vibration-free, protected from abrupt temperature changes (maximum ambient temperature range is 10 °C to 35 °C (50 °F to 95 °F), and drafts. Such changes may upset the temperature stability in the course of an analysis or preparation.
- B. Enough tabletop space should be allowed for the installation of recorders, integrators, computers, etc. Allow sufficient space on all sides of the GC for easy access.
- C. Make sure that there is adequate space for the installation of gas cylinders. Cylinders should be securely fastened to the wall or table. Check with O.S.H.A. or the CGA for proper handling of gas cylinders.
- D. An electrical outlet (ac) should be near the location where the GC is to be installed. If the outlet is not a 3-pin type, make sure that a good ground connection is available, since a good ground is necessary for proper operation. The ac outlet should be connected to a circuit that is not heavily loaded with other electrical equipment because input voltage to the instrument should be steady for optimum operation stability.

If the ac line voltage varies, consideration should be given to the installation of a stabilizing transformer at the ac outlet.



MAKE SURE ALL SWITCHES ON THE FRONT AND BACK OF THE INSTRUMENT ARE IN THE "OFF" POSITION BEFORE PLUGGING THE INSTRUMENT "IN".



DO NOT TURN THE INSTRUMENT "ON" AT THIS TIME!



IF PLACING MODULES ON TOP OF EACH OTHER, ALWAYS PLACE THE OVEN MODULE ON TOP OF THE DETECTOR MODULE.

4.4 Gas Connections (General-see page 22)

The AR710 Series GCs require the following gases:

- A. Ultra high purity argon (Ar), N6.0 or purified argon for the carrier gas. The ultra high purity argon gas cylinder should be equipped with an ultra high purity two-stage argon regulator.
- B. Clean dry air for actuating the valves. The air cylinder should be equipped with an ordinary two-stage air regulator.
- C. All tubing connections for the carrier gas, sample gas and actuator gas are 1/8-inch. To prevent contamination of the GC and the extremely sensitive detector by grease, oil or chemical residue the following procedure **MUST** be performed for purging all stainless steel tubing of possible contaminants **PRIOR** to connections to the gas chromatograph.
 - i. The carrier gas inlet tubing must be connected directly to Ultra High Purity Argon.
 - ii. The sample inlet tubing should be connected to the sample cylinder.
 - iii. Connect carrier gas to inlet marked carrier.
 - iv. A reference (calibration) gas e.g. 5 ppm H₂, O₂, N₂, CH₄ and CO in argon to inlet marked sample.
 - v. Connect outlet of the GC to the detector inlet.

4.5 Carrier Gas Purity



ARGON CARRIER GAS *MUST* BE GRADE 6 (N6.0) OR BETTER. ARGON GRADES LOWER THAN GRADE 6 MUST BE PASSED THROUGH AN ARGON GAS PURIFIER. FAILURE TO COMPLY WITH THIS WILL CANCEL THE WARRANTY OF THE SYSTEM.

The AR710 Series GCs are instruments which can determine impurities in argon at the parts per billion (ppb) level. However, in order to reach this level of sensitivity, **EXTREME CARE** must be taken to ensure that there are no leaks in the system and that the carrier gas is as pure as can possibly be.

NOTE



If for some reason the carrier gas is not as pure as the sample gas, reversed peaks can occur for gases which are in lower concentration in the sample gas.

By using a carrier gas purifier in the argon line, N6.0 grade argon can be purified to a level cleaner than chromatographic grade argon.

NOTE

It is highly recommended that the operator obtains and reads the gas purifier operating instructions from your gas purifier manufacturer.

To prevent low level impurities from appearing in the baseline, the purifier must be heated. Refer to the manufacturers instructions.

4.6 Carrier Gas Flow Adjustment

- A. Turn the Ultra High Purity Argon *ON* at the regulator and set the head pressure to approximately 75 psig.
- B. Adjust column flow rate to 40 mL/min. Carrier flow is measured using the “Detector Flow” meter on the front of the instrument.

4.7 Actuator Gas Adjustment

- A. Turn *ON* the actuator gas at the regulator and set a head pressure of approximately 40 psig.

4.8 Sample / Calibration Gas Flow Adjustment

- A. Turn *Sample / Calibration Gas ON* at the regulator and set head pressure to 3-5 psig.
- B. Adjust *Sample / Calibration* flow rate to 30 mL/min. Flow rate is measured using the Sample Flow Meter on the front of the instrument.

4.9 Leak Check

- A. After all connections have been made and the gases are flowing, it is **VERY IMPORTANT** that they are tight and free from leaks. Leaks in the carrier gas lines will cause baseline drift, noise, and will interfere with the extremely sensitive detector (contamination).



Power to the instrument is to remain “OFF” throughout this procedure.



A leak check should be made of the entire GC system *PRIOR* to instrument operation.



DO NOT use soap solution as it will contaminate the system. The use of GOW-MAC Gas Leak Detector Model 21-070 is *HIGHLY* recommended.

B. Areas to Check

1. Column connections.
2. Carrier gas connections.
3. Sample gas connections.

NOTE



Leak checks should be run periodically and are a MUST when new columns are installed or gas connections are made.



WARNING

All Gases are Dangerous

4. During handling and use of compressed gas cylinders, be certain to use applicable safety precautions described by your local compressed gas supplier, the Compressed Gas Association, and/or O.S.H.A. regulations.

GAS CONNECTIONS FOR AR720/22

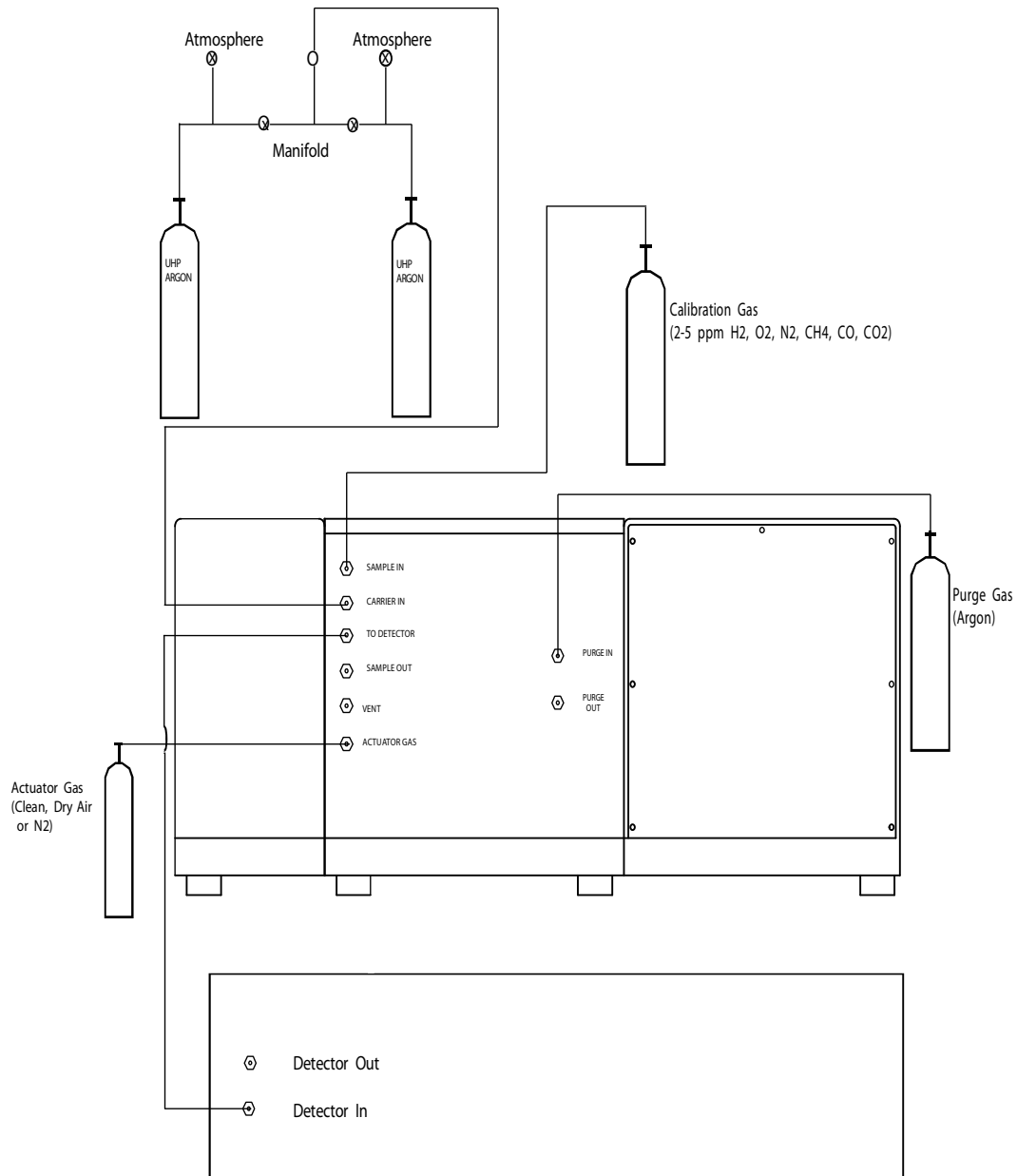

Operating Controls

The operator should become very familiar with these controls and their functions BEFORE operating the instrument. Refer to Figures 5.1 and 5.2.

5.1 Controls - Front Panels

Control Module (Figure 5.1)

- A. **Detector Current Display** - Displays a current proportional to the light intensity in the detector
- B. **Detector Current Adjust** - Allows the operator to adjust the power to the detector. High power (55) is used for impurities 0-50 ppm, normal power (50) is used for impurities 0-5 ppm
- C. **Zero Adjust** - This pot is used to manually bring the baseline to zero.
- D. **Auto Zero (A/Z) On-Off** - This switch is used to override the Auto Zero circuit
- E. **Auto Zero (A/Z)** - A push button switch which manually activates the Auto Zero circuit. The LED next to the button is an indicator for the A/Z, when the A/Z is activated either manually or automatically, the LED switches off.
- F. **Start/Run Switch** - To supply maximum power to the detector for starting.
- G. **Baseline Indicator** - Shows the baseline position.
- H. **Detector Flow Meter** - Measures the flow through the detector.
- I. **Inspection Window** - To view the discharge.

Oven Module (Figure 5.2)

- J. **Column Temperature Control(s)** - Sets the temperature of the column oven(s). Use the Up- and Down- Arrow keys to adjust the temperature setpoint. Series AR710 has one Column Temp. Controller (COL 1), and the Series AR720 has two Column Temp Controllers (COL 1 and COL 2).

Left (Upper) Display: In the Home Page, displays the process value, otherwise displays the value of the parameter in the lower display.

Right (Lower) Display: Indicates the set point or output power value during operation, or the parameter whose value appears in the upper display.

Advance Key: Advances through parameter prompts.

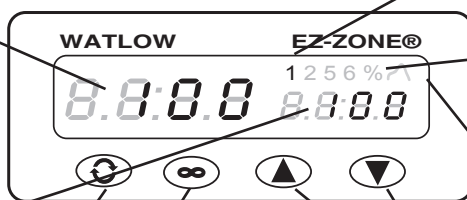

Infinity Key: Press to back up one level, or press and hold for two seconds to return to the Home Page.

Output Activity: Number lights indicate activity of outputs 1, 2, 5 and 6.

Percent Units Indicator: Lights when the controller is displaying values as a percentage or when the open-loop set point is displayed.

Profile Activity; Lights when a profile is running. Flashes when a profile is paused.

Up and Down Keys; In the Home Page, adjusts the set point in the lower display. In other pages, changes the upper display to a higher or lower value, or changes a parameter selection.

Responding to a Displayed Message

An active message will cause the display to toggle between the normal settings and the active message in the upper display and **ATTN** in the lower display

Your response will depend on the message and the controller settings. Some messages, such as Ramping and Tuning, indicate that a process is underway. If the message was generated by a latched alarm or limit condition, the message can be cleared when the condition no longer exists. If an alarm has silencing enabled, it can be silenced.

Push the Advane Key to display **.9NR** in the upper display and the message source (such as **L.HI**) in the lower display.

Use the Up and Down arrow keys to scroll through possible responses, such as Clear **CLR** or Silence **S.L**. Then push the Advance or Infinity Key to execute the action.

ER.1 Error Input 1

H.ER Heater Error

- K. ***GSV Switch*** - The GSV switches the sample loop from the sample line into the carrier line. Mid-position allows control from the contacts on rear panel and automatic control.

When the Gas Sample Valve, GSV on the front panel is set to REMOTE (mid) position, the valve may be actuated by supplying a TTL SIGNAL between the relevant pins on the rear panel connector.

Note: Contact closure is available upon request.

- L. ***Carrier Gas Flow Control*** - Sets carrier flows through the columns.
- M. ***Sample Flow Meter*** - Measures the sample flow out of the GC.

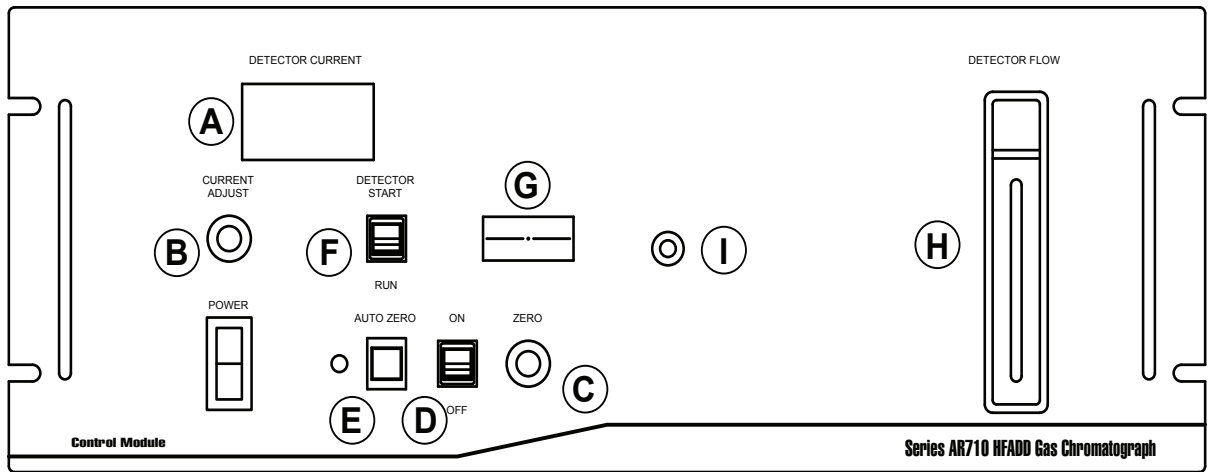

Control Module - Front: AR710 or AR720

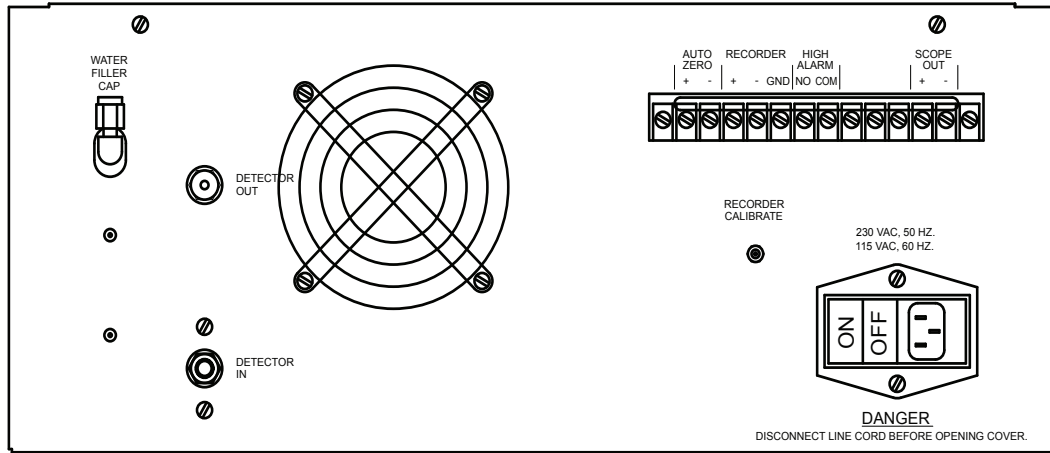

Control Module - Back: AR710 or AR720

Figure 5.1

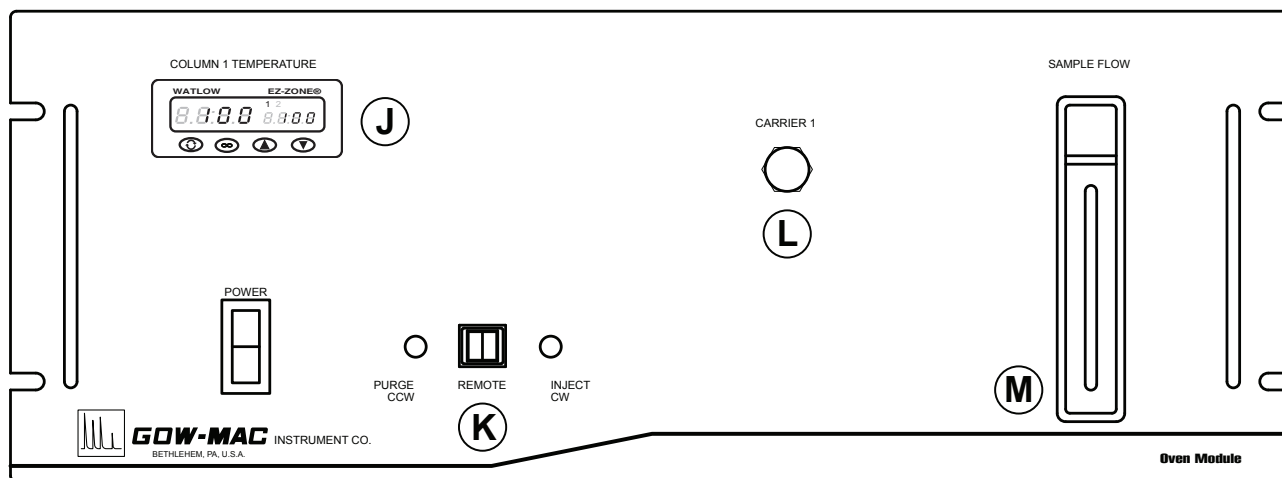

Oven Module - AR710 (1 Valve)

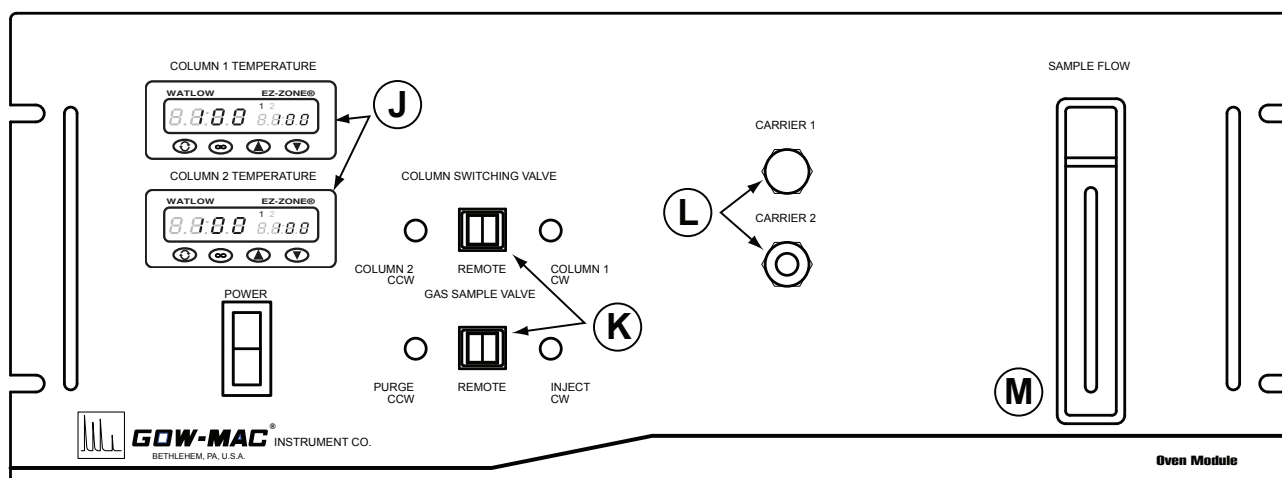

Oven Module - AR720 (2 Valves)

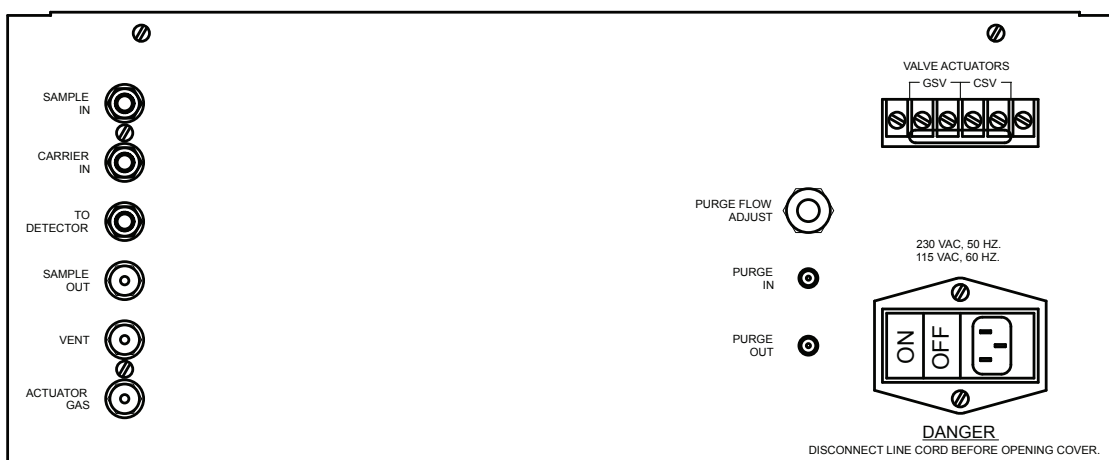

Oven Module - AR710 or AR720 (1 or 2 Valves)

Figure 5.2

6 Operation

6.1 General

The Analyst should be familiar with the techniques of chromatography, the functions of all instrument controls, the operation of the recorder, and the characteristics of the column used **PRIOR** to running samples.

6.2 Initial Operation

A. Carrier Gas Flow Adjustment

- i. Make Sure that ALL switches are in the 'OFF' position.
- ii. Set flow as described in INSTALLATION section.
- iii. Check for leaks as described in INSTALLATION section.

B. Actuator Gas Adjustment

- i. Set head pressure to approximately 40 psig.
- ii. **Allow 4 hours for the system to purge before turning the power "on".**

6.3 Warm Up

- A. Plug the instrument into the appropriate AC outlet.
- B. Set desired **COLUMN TEMPERATURE(S)**, e.g. 80 °C, by using the UP- and DOWN-Arrow keys located on the COL 1 Temperature or COL 2 Temperature Controller.
- C. Allow adequate time for the column oven(s) to reach set temperature. Refer to QC documentation which has been supplied with this instrument.
- D. Observe the **DISCHARGE CURRENT** display to determine if the discharge is on. The discharge is 'ON' if a current is displayed. If no current is displayed after 5 minutes, turn the START/RUN Switch to *START*. A current should be displayed in 1 to 2 minutes. After the current appears, return to *RUN* mode.

The delay realized in achieving a current is usually due to the purging of residual air in the instrument.

- E. All air should be removed from the system after running the instrument overnight.



THE ULTRAVIOLET RAY (UV) IS HARMFUL TO THE NAKED EYE. WHEN CHECKING THE SYSTEM IT IS IMPORTANT THAT THE DISCHARGE IS VIEWED USING A UV ABSORBING FILTER SUCH AS BOROSILICATE GLASS OR POLYSTYRENE.

- F. The discharge can be seen through the inspection window on the front panel.
- G. The discharge seen should be a stable bright white 0.5 mm light in the center of a less intense blue 3 mm discharge.
- H. If the discharge is oscillating the carrier gas is impure due to leaks or insufficient purge time.
- I. Adjust detector current to "50" for samples containing up to 5 ppm impurities.

6.4 Use of a Strip Chart Recorder

The AR710 Series GCs are suitable for use with almost any strip chart recorder of the potentiometric type (<1 mV, 10 mV, or other). An adjustable chart drive is also recommended: 40, 20 10, 4, 2, 1, cm/min. and hour.

A. Operation of Chart Recorder

- i. Switch off the *A/Z*, (Auto-Zero).
- ii. Observe the detector output signal for drift. If drift is more than 1% (of chart width) per minute, allow more time for the detector to stabilize or column bleed to minimize.
- iii. When the baseline has stabilized, readjust the *ZERO* control for desired zero level on the chart.
- iv. Refer to the recorder's operating manual for correct chart speeds, warm-up times, etc.
- v. Switch "on" the *A/Z*.

6.5 Use of a Computing Integrator

The AR710 Series GCs may also be used with a computing integrator. After the integrator is properly connected to the analyzer, it may be turned 'ON'. At this time, the electrical or recorder zero should be established and reference should be made to the integrator's operating manual.

6.6 Use of Data Handling Software

The AR710 Series GCs may also be used with computer software for data handling and reduction. Reference should be made to the software's operating manual.

6.7 Calibration

- A. After allowing for sufficient time for the instrument to equilibrate, recheck the operating parameters.

- B. It is necessary to purge the *SAMPLE LOOP* for a sufficient time to remove all traces of room air and old sample. This may take 5 to 10 minutes at a flow rate of 50 to 100 mL/min. ***THIS IS ESPECIALLY TRUE IF YOU HAVE JUST CHANGED SAMPLES.***

NOTE  ***There may be residual air trapped in the sample regulator bourdon tubes which must also be purged to give consistent results at low levels.***

6.8 Initial Analysis

The operation of the instrument cannot be evaluated without the injection of a known sample. Choose a calibration gas to suit your application, e.g. 5 ppm H₂, O₂, N₂, CH₄, CO, etc. Inject a sample of pure argon gas as a zero reference gas.

6.9 Sampling

When operating at low levels (ppb) it is very important to establish a correct sampling technique. Allow sufficient time for sample regulator and line to purge. Once the sample and reference lines have been purged keep them clean by flowing sample/reference or clean argon through the lines. To verify that all of the air has been purged, inject a sample of argon containing equal concentrations of N₂ and CH₄. The response is always higher for CH₄.

6.10 Automatic Valve Actuator

The sample valve can be operated automatically by providing a contact closure on the relevant pins of the tag block located on the back panel of the instrument. (Refer to the maintenance manual).

6.11 Standby and Shutdown Procedure

For maximum stability and minimal disruption and downtime, the instrument should ***ideally remain ON*** with optimized settings and flows between analyses. The following ***optional*** procedures may be employed if continuous operational conditions are not feasible.

A. Overnight Conditions

- i. Turn the recording device *OFF*.
- ii. *Carrier Gas* and all other settings should remain *unchanged*.

B. For Less Than Four (4) Weeks



The following procedure may result in an extended recovery time until instrument stability and peak performance are again achieved upon return to optimized analysis flows.

- i. Turn the recording device *OFF*.
- ii. Turn *Sample Gas OFF*.
- iii. Reduce *Carrier Gas* flow to 10 mL/min.
- iv. All other settings should remain *unchanged*.

C. For More Than Four (4) Weeks



The following procedure will require at least 24 hours recovery time until instrument stability and peak performance are again achieved upon return to optimized analysis settings and flows.

- i. Turn the recording device *OFF*.
- ii. Turn *Sample Gas OFF*.
- iii. Cool the purifier down to ambient.
- iv. Turn the purifier *OFF*. [Refer to purifier manufacturer's instructions for shutdown procedure.]
- v. Turn the AR710/AR720 analyzer *OFF*.
- vi. Allow the *carrier gas* to flow for 1 to 2 hours and then turn the *carrier gas OFF*. The carrier gas can also be reduced to 10 mL/min. instead of completely shutting it off. This will keep the system purged. With the instrument at ambient room temperature there will not be a need to periodically increase the carrier flow rate.

Application Information

The following Chromatogram is a result of a sample injection onto a GOW-MAC AR710 Series GC system. It will give you (the Operator) an indication of what your Chromatogram should look like when looking for impurities in an argon sample gas. It is not to be construed as a guarantee of what to expect from your particular Instrument as conditions may be different.

7.1 Application Technique (Example)

Instrument:	Series AR710 Gas Chromatograph
Detector:	High Frequency Argon Discharge Detector (HFADD)
Sample:	1 ppm Argon Reference Gas
Oven Temperature:	80 °C
Detector Current:	47 mA
Carrier Gas:	N6.0 Argon, 40 mL/min
Column:	3-m x 1/8-inch Molecular Sieve 13X
Valve Type:	6-Port Gas Sample Valve (with 2 mL loop)

Figure 7.1

Chrom Perfect Chromatogram Report

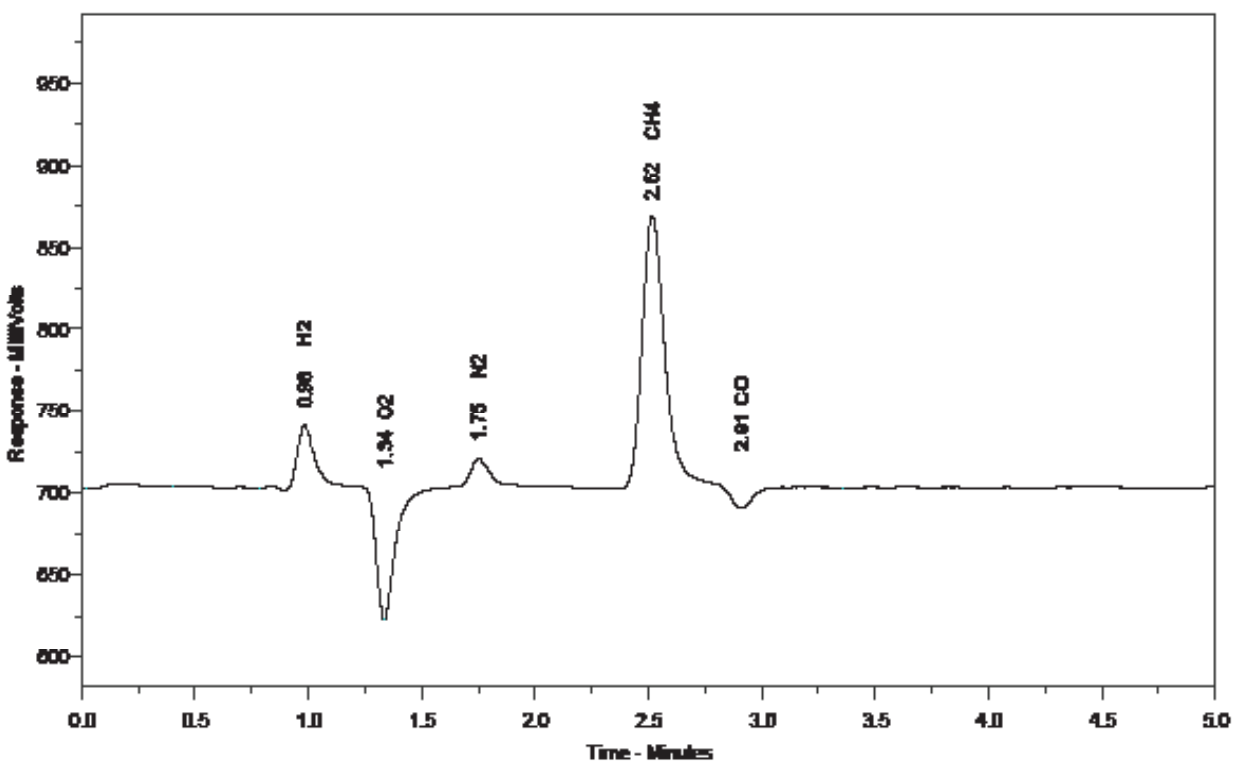

Name of Peak	Retention Time	Area	Amount
H ₂	0.98	205288	1.86 ppm
O ₂	1.34	465894	2.33 ppm
N ₂	1.75	104985	2.18 ppm
CH ₄	2.52	1128221	2.00 ppm
CO	2.91	101133	1.93 ppm

Chart 7.1

Maintenance & Servicing

8.1 Columns

NOTE

When ordering a new column, please specify the following information: instrument model number, serial number, length, diameter and material (refer to flow diagram enclosed for column details)

- A. The Series AR710 or AR712 GC is supplied with one column (3-m x 1/8-inch Molecular Sieve 13X). The Series AR720 or AR722 GC is supplied with a 3-m x 1/8-inch Molecular Sieve 13X column and a 3-m x 1/8-inch HayeSep Q column.
- i. Care should be exercised to ensure that the column(s) is/are used within its operating limits. Maximum temperature is 150 °C.
- ii. Columns for the AR710 Series GCs can be purchased from by contacting us directly at:

**GOW-MAC Instrument Co.
277 Brodhead Road
Bethlehem, PA 18017 U.S.A.**

Phone: (610) 954-9000
Fax: (610) 954-0599
E-mail: sales@gow-mac.com

8.2 Water Injector

The *Water Injector* which is fitted between the column and the detector should be topped up every 3 months.

- A. To Refill
- i. Remove the cap from the water injector at the rear of the analyzer.
- ii. Using a syringe fill the injector with clean water until it overflows.
- iii. Replace cap.
- iv. No interruption in the carrier gas has taken place and the operation should continue as normal.

Replacement Parts

When ordering replacement parts for your AR710 or AR720 Series GC please specify the serial number and the voltage of the instrument.

Description	Part No.	
Heaters	Column Oven Heater, 100 W (115 V)	124-181
	Column Oven Heater, 100 W (230 V)	124-182
	Enclosure Heater, 100 W (115 V)	124-218
	Enclosure Heater, 100 W (230 V)	124-219
Temperature Control	Oven Temperature Controller	124-262
Electronic Modules	Hi-Volt Power Supply Unit	123-252
	Display Interface	123-253
	Oscillator PCB	123-254
	Signal Amp/Auto-zero	123-255
	TTL to Relay Driver Interface	123-188
Detector	High Frequency Argon Discharge Detector	15-185-GMB
Electronic Parts & Controls	Potentiometer, 20K (coarse zero, current adjust)	111-178
	Potentiometer, 1K trim, panel mount	111-197
	Vacuum Tube	117-340
	Transformer, 300 V (115 V)	118-150
	Transformer, 300 V (230 V)	118-151
	Solid State Relay, 25 A	122-114
	Finger Guard, Back Panel	127-246
	Panel Meter, 3-1/2 digit LED display	128-182
	Fan, Back Panel (115 V)	124-156
	Fan, Back Panel (230 V)	124-162
	Probe, platinum with connector	124-175-T-1
	Sample Loop, 2 mL	180-454
	Solenoid Valve (115 V) with connector	155-153
	Solenoid Valve (230 V) with connector	155-152
	Pressure Regulator, st. st. diaphragm	180-559
	Metering Valve	180-571
	Flowmeter 10-100 cc Air/min.	180-216

Column Assemblies

AR710 Single Column Unit, 115 V	Molecular Sieve 13X	152-490
AR712 Single Column Unit, 230 V.....	Molecular Sieve 13X	152-490-230
AR720 Dual Column Unit, 115 V	Molecular Sieve 13X Hayesep Q	152-490 152-491
AR722 Dual Column Unit, 230 V.....	Molecular Sieve 13X Hayesep Q	152-490-230 152-491-230

Valves

Single Valve Unit:		
6-port Gas Sample Valve		181-612ZP
Dual Valve Units:		
4-port Gas Sample Valve		181-609ZP2
10-port Gas Sample Valve		181-611ZP2

Drawings & Schematics

AR710 & AR712 (Single Column Instrument)

Drawing No. B-19194 115 V & 230 V Flow diagram

AR720 & AR722 (Dual Column Instrument)

Drawing No. B-19224 115 V & 230 V Flow diagram

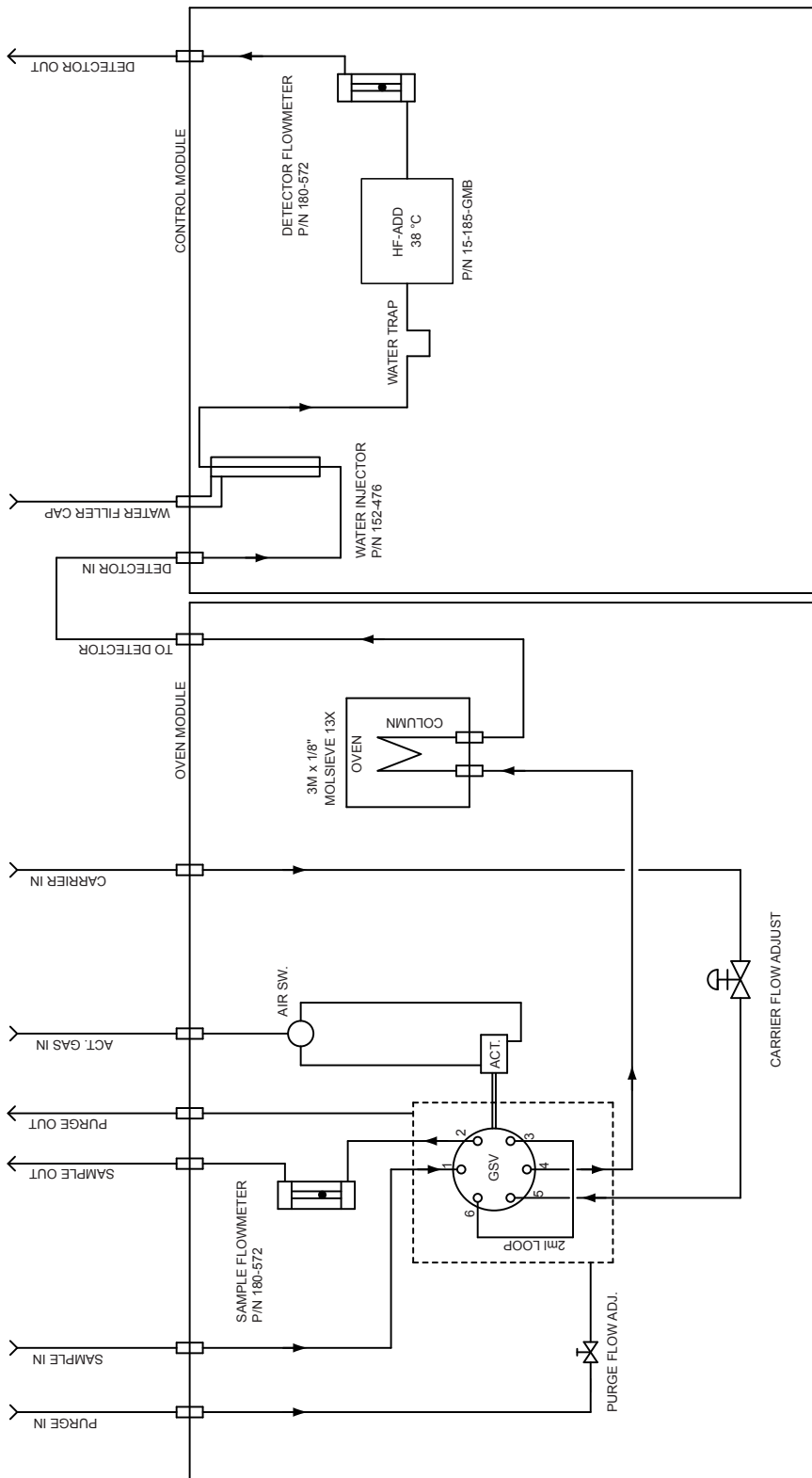

DWG. NAME		FLOW DIAGRAM AR710 & AR712	
DATE	SMIL	MATERIAL	FINISH
02/21/01			
CHK.			
SCALE	N.T.S.	DO NOT SCALE	
		UNLESS NOTED	
		.X ± 0.4	
		.XX ± 0.02	
		HOLES ± 0.03	
		REV. NO.	4
ECO			ANGULAR ± 1°

NO	DATE	BY	CHANGE
4	8/23/10	SMIL	UPDATED: Pressure Gauge Removed
3	8/5/08	KH	UPDATED
2	7/8/08	KH	UPDATED
1	1/31/08	KH	UPDATED

FILE: B1919R2.DWG

CCW - PURGE

CW - INJECT

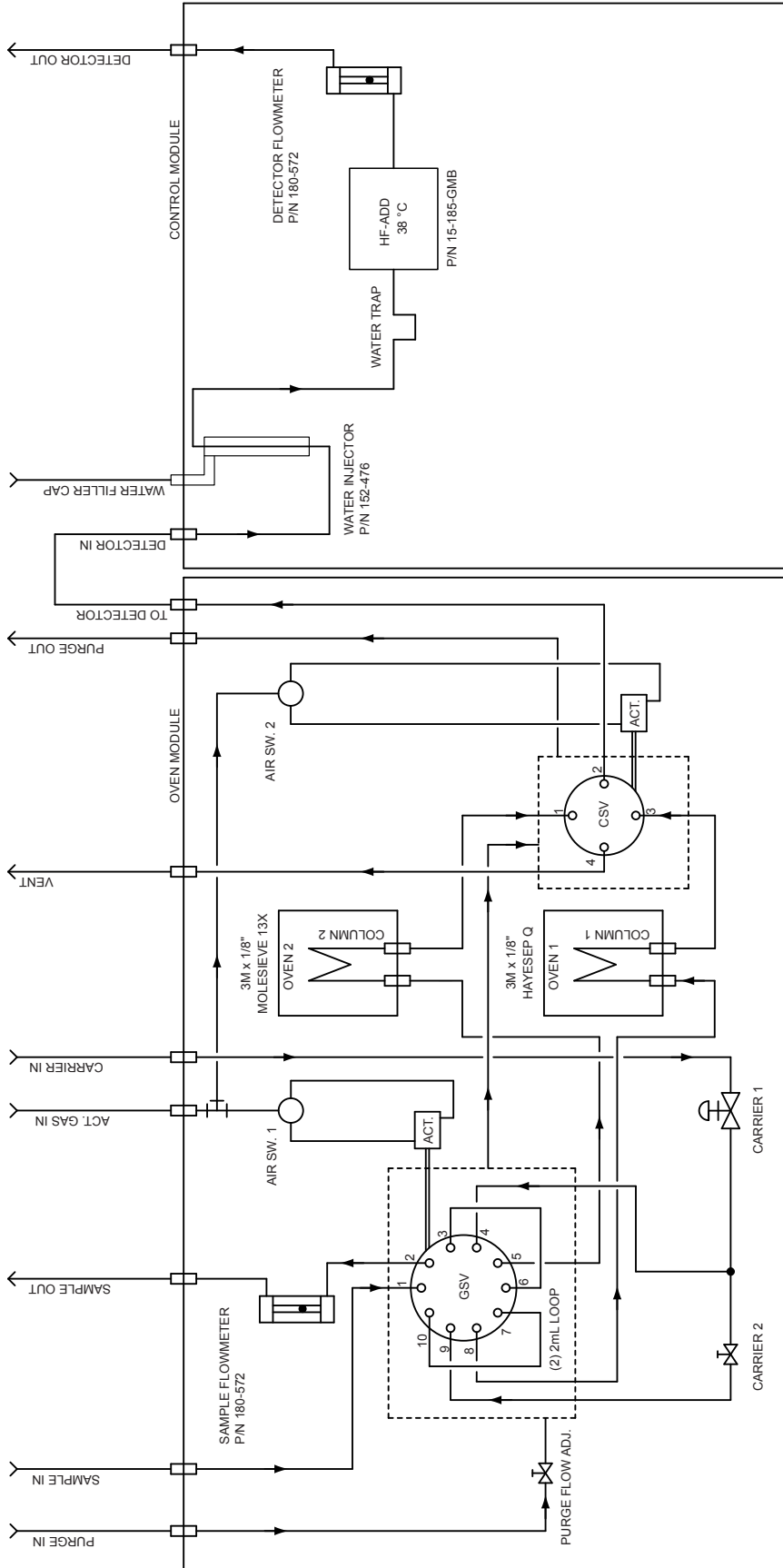

DWG. NAME		FLOW DIAGRAM	
DATE	SJML	ART20 & AR712	
5/03/01 <td>5/03/01 <td>MATERIAL</td> <td></td> </td>	5/03/01 <td>MATERIAL</td> <td></td>	MATERIAL	
08/23/10 <td>5</td> <td>UPDATED: REMOVED PRESSURE GAUGE</td> <td></td>	5	UPDATED: REMOVED PRESSURE GAUGE	
8/6/08 <td>4</td> <td>UPDATED</td> <td></td>	4	UPDATED	
7/10/08 <td>3</td> <td>UPDATED</td> <td></td>	3	UPDATED	
3/6/08 <td>2</td> <td>UPDATED</td> <td></td>	2	UPDATED	
	1	COLUMN WAS SILICA GEL	
	NO	DATE	BY
			CHANGE
FILE: B19224R3.DWG			
V1		V2	
CW - PURGE		CW - INJECT	
CW - COLUMN 2		CW - COLUMN 2	

GOW-MAC
INSTRUMENT CO.
277 MIDWAY ROAD BETHLEHEM, PA 18017-8000

B-19224

Health and Safety Declaration for the Return of GOW-MAC Instrument Co. Equipment

In order to protect our employees from exposure to various hazards, the following statements and/or questions **MUST** be answered by you. Fill out this document in its entirety and either fax or e-mail it to GOW-MAC Instrument Co., Attn: Repair Dept, **BEFORE** returning the product.

The instrument/part being returned **will not** be accepted into GOW-MAC's facility until we receive this completed document, along with a **PO or Credit Card**. Once approved for return by our Chemical Safety Officer, a **Return Materials Authorization (RMA) number** and shipping instructions will be issued. *All applicable regulations should be followed when returning instrumentation, and/or parts.*

Customer to Record the Following:

Model # / Part # _____

Serial #: _____

Service Technician spoken to: _____

Today's Date: _____

IF THIS FORM IS NOT APPROVED BY OUR CHEMICAL SAFETY OFFICER, THE INSTRUMENT/PART WILL NOT BE PERMITTED INTO OUR FACILITY FOR SERVICING!

- A) Brief explanation of issue: _____
- B) Briefly list the application(s) for which the instrument/part was used, as well as any and all chemicals, gases, and/or materials analyzed and their concentrations. **(Must be filled in)**: _____
- C) Is there the possibility of internal or external contamination on or in this instrument/part?
 Yes – see below No – proceed to D.

Please check the appropriate box.

- Chemicals or Substances That Are Hazardous to Health
- Blood, Body Fluids, (e.g. Urine, Secretions), Pathological Specimens
- Regulated Medical Wastes
- Infectious Substances or other Bio-Agents (e.g. Protein, Enzymes, Antibodies)
- Radioactive Isotopes used in the area. Detail type (ECD, Isotopic Labels, etc) and Activity in Micro Curies
- Biodegradable Material That Could Become Hazardous
- Other Hazards _____

If any of the above boxes are checked the following statements and/or questions must be answered.

1. Specifically describe where (on or in) the instrument/part there could be any residual contamination (for example: blood spill on the surface). _____
2. Provide details of these hazards. Include names, Material Safety Data Sheets (MSDS), and concentration of contaminants, where possible. _____
3. Describe the method of decontamination used. Attach Procedure. _____

- D) I declare that the above information is true and complete to the best of my knowledge. I acknowledge that any inconsistencies between the condition of the instrument and the statements made on this form will delay the repair process.

Authorized signature _____ Date: _____

Name (Printed) _____ Phone number: _____

Company name: _____ Fax number: _____

Shipping address: _____

City: _____ State/Country: _____ Zip: _____

E-mail address: _____

BEFORE item can be shipped, fax completed form to: (610) 954-0599 or e-mail it to: repairs@gow-mac.com

For GOW-MAC Use Only:	Signed: _____	Date ____/____/____
<input type="checkbox"/> Passed Safety Inspection. OK to proceed to Repair Dept.	Chemical Safety Officer	Comments: () None
<input type="checkbox"/> Failed safety inspection. DO NOT proceed to Repair Dept.	RMA No: _____	() On Back >>>>



REP-005
Health-Safety Declaration Doc – ONLINE
Rev.7 1/28/2022, kj

