

Operating Manual

**Series 400/402 & 400-P/402-P
Thermal Conductivity
Gas Chromatograph**

Series 400: 120 V, 50/60 Hz
Series 402: 230 V, 50/60 Hz

August 2025
Rev. 15

**READ INSTRUCTIONS
BEFORE OPERATING**



Contents

Disclaimers	5
Important Information	6
Warranty	7
Important Warning	9
Important: Gas Flow Adjustment Note	10
Chapter 1 - Safety Precautions	11
Chapter 2 - Specifications	13
Chapter 3 - Installation	15
Chapter 4 - Operation.....	23
Chapter 5 - Microscale Prep.....	31
Chapter 6 - Valves	35
Chapter 7 - Software	39
Chapter 8 - Experimental Run Through.....	41
Chapter 9 - Maintenance.....	47
Chapter 10 - Replacement Parts.....	53
Chapter 11 - Mechanical Drawings.....	55

DISCLAIMERS

The information in this document is subject to change without notice. This manual could include technical inaccuracies or typographical errors. Changes are made periodically to the information herein; these changes will be incorporated in subsequent revisions of the manual. GOW-MAC® Instrument Co. reserves the right to make improvements and/or changes to the product(s) and/or programs described in this manual at any time and without notice.

All information referred to and/or included in this report is current as of the original issue date of this manual. GOW-MAC® Instrument Co. makes no warranty or representation with respect to the accuracy of the information or with respect to the suitability of the use of such information outside GOW-MAC® Instrument Co., nor does GOW-MAC® Instrument Co. assume responsibility for any injury or damage which may result, directly or indirectly, from the use of such information.

This document contains proprietary information which is protected by copyright. All rights are reserved. No part of the document may be photographed, reproduced, or translated into another language without the prior written consent of GOW-MAC® Instrument Co.

The warranties made by GOW-MAC® Instrument Co. with respect to the product are voided if the product is not used and serviced in accordance with the instructions in this manual.

Please protect yourself and your employees by following these operating instructions. We encourage our customers to write or call for any additional information relative to the use or repair of this instrument.

TRADEMARK AND PATENT INFORMATION

®GOW-MAC is a registered trademark of GOW-MAC Instrument Co.
in the United States and other countries.

Other trademarks used herein are trademarks or registered trademarks of their respective owners.

Swagelok® - is a registered trademark of Crawford Fitting Co.
Parker® - is a registered trademark of Parker Hannifin Corp.
Gyrolok® - is a registered trademark of Hoke, Inc.

Copyright© 2005-2015 by GOW-MAC® Instrument Co.

LIABILITY Buyer assumes all responsibility for warning and protecting its employees and independent contractors with respect to all hazards to persons and property in any way connected with the Equipment and the use thereof. Seller's liability for any claim of any kind hereunder, whether or not based on contract, tort (including negligence), strict liability, warranty, or any other grounds, shall not exceed the purchase price of the Equipment or the portion of the purchase price attributable to any part or parts of the Equipment in respect to which such claim is made. Seller shall not be liable for any special, indirect, incidental, or consequential damages. Without limiting the generality of the foregoing, Seller shall have no liability with respect to the results obtained by use of the Equipment, whether in terms of product condition, operating cost, general effectiveness, success or failure, or regardless of any statement made in any written proposal submitted by Seller. It is expressly understood that any technical advice furnished by Seller with reference to the Equipment is given gratis and Seller assumes no obligation or liability for the advice given or results obtained, all such advice being given and accepted at Buyer's risk. Each party hereby agrees to indemnify and hold the other party harmless from any actions, lawsuits, demands, claims, losses, expenses, costs, including but not limited to legal fees, and damages arising from the injury, illness or death of the indemnifying party's employees in any way related to the Equipment, whether or not such injury, illness, or death is claimed to have been caused by, resulted from, or was in any way connected with the negligence of the party to be indemnified.

PROPRIETARY INFORMATION Buyer agrees to maintain all proprietary information disclosed by Seller, including such proprietary information obtainable upon examination of the Equipment, in confidence and to refrain from any disclosure thereof to any third party (including any affiliate of Buyer), for any purpose, without the prior written consent of Seller. Buyer agrees to use said proprietary information solely for purposes of maintaining and operating the Equipment, and to refrain from any use thereof to design, construct, have constructed and/or operate any duplication or modification of the Equipment, or from any other use thereof, without the prior written consent of Seller.

IMPORTANT INFORMATION

These instructions are written for personnel operating the GOW-MAC® Series 400 Isothermal TCD Gas Chromatograph. Read and understand the safety precautions in this manual to become familiar with the safe practices for operating this equipment.

Dangers, Warnings, Cautions, and Notes

Dangers, Warnings, Cautions, and Notes appear throughout this manual. A sample of each statement appears below. Within each sample, a definition of the statement type and its purpose is given.



DANGERS alert you to an immediate hazard that causes serious injury or death and requires special precautions to be taken.



WARNINGS alert you to a potential hazard that causes serious injury or death *under certain conditions*.



CAUTIONS alert you to a non-immediate or potential hazard or an unsafe practice that presents a minor threat of personal injury or damage to equipment, data, or processes.



NOTES emphasize or remind you of an important piece of information.

Warranty

THE SERIES 400 TCD GC SOLD BY GOW-MAC® INSTRUMENT CO. IS WARRANTED FOR A PERIOD OF ONE (1) YEAR AGAINST DEFECTS IN MATERIALS AND WORKMANSHIP. THE TERMS OF THIS WARRANTY ARE AS FOLLOWS:

1. The warranty period begins with the shipping date of the equipment to the original purchaser.
2. Certain parts such as septa, batteries, fuses, glass accessories, detectors, filaments, columns, etc., are expendable in normal use, and their service life is unpredictable. Such items are not covered by this warranty.
3. Filaments of thermal conductivity detectors are not covered by this warranty.
4. Hydrogen Palladium Tubes are not covered by this warranty.
5. All requests for service or repair under this warranty must be received within the warranty period by GOW-MAC® or its authorized representative. All repairs are made at GOW-MAC plants or at the office of authorized representatives.
6. All repairs, adjustments, and other service under this warranty shall be performed free of charge to the purchaser. However, warranty service and repairs shall be limited to equipment malfunctions which, in the opinion of GOW-MAC®, are due or traceable to defects in original materials or workmanship. Instrument malfunctions caused by abuse or neglect of the equipment are expressly not covered by this warranty.
7. Instrument parts which have been repaired or replaced during the warranty period are themselves warranted only for the remaining unexpired portion of the original six month warranty.
8. Repairs, adjustments, and service performed after expiration of the six month warranty period shall be charged to the purchaser at the then current prices for parts, labor, and transportation.
9. This warranty attaches to the equipment itself and is not limited to the original purchaser. Unexpired portions of the warranty are thus transferable to subsequent owners.
10. GOW-MAC® expressly disclaims any liability to users of its products for consequential damages of any kind arising out of or connected with the use of its products.
11. Except as stated in Sections 1 through 8 above, GOW-MAC® makes no warranty, expressed or implied (either in fact or by operation of law), statutory or otherwise; and, except as stated in Sections 1 through 8 above, GOW-MAC® shall have no liability under any warranty, expressed or implied (either in fact or by operation of law), statutory or otherwise.
12. Statements made by any person, including representatives of GOW-MAC® which are inconsistent or in conflict with the terms of this warranty shall not be binding upon GOW-MAC® unless reduced to writing and approved by an officer of the Company.
13. This warranty shall be governed by the laws of the Commonwealth of Pennsylvania.

IMPORTANT WARNING

THIS MANUAL MUST BE CAREFULLY READ BY ALL INDIVIDUALS WHO HAVE OR WILL HAVE THE RESPONSIBILITY FOR INSTALLING, USING, OR SERVICING THE PRODUCT.

Like any piece of complex equipment, the SERIES 400 ISOTHERMAL TCD GAS CHROMATOGRAPH will perform as designed only if it is installed, used and serviced in accordance with the manufacturer's instructions. OTHERWISE IT COULD FAIL TO PERFORM AS DESIGNED AND PERSONS WHO RELY ON THIS PRODUCT FOR THEIR SAFETY COULD SUSTAIN SEVERE BODILY INJURY OR DEATH.

The warranties made by GOW-MAC Instrument Co. with respect to the product are voided if the product is not installed, used and serviced in accordance with the instructions in this manual.

Please protect yourself and your employees by following these operating instructions. We encourage our customers to write or call for any additional information relative to the use or repair of this instrument.

Technical Support

GOW-MAC Instrument Co.
277 Brodhead Road
Bethlehem, PA 18017 U.S.A.

Tel: (610) 954-9000

Fax: (610) 954-0599

E-mail: sales@gow-mac.com

IMPORTANT

Gas Flow Adjustment Notes

1. Carrier pressure required varies with the length and packing material of the installed columns. Pressure must be at least 15 psig to close the pressure switch and energize the detector current. Thirty (30) psig is adequate for most columns.
2. Before reading measurement, allow five (5) minutes for the rate to equilibrate after each adjustment.
3. Inert carrier gas **MUST** be flowing through **both columns A and B as well as sides A & B** of the TC detector **at all times. THIS IS EXTREMELY IMPORTANT and NECESSARY to preserve the filaments!**

Failure to set flow rates on both sides causes oxidation and destruction of the filaments in the presence of oxygen.

Chapter 1 - Safety Precautions

- 1.1 This section is designed to bring special attention to specific areas or practices that may pose particular hazards to personnel and/or equipment safety only. For complete installation instructions, see Section 3.

It is in the operator's best interest to read this section to ensure the safe operation of the instrument.

1.2 ELECTRICAL HAZARDS

- A. This instrument employs voltages that are **dangerous**. **EXTREME** caution must be exercised when working with this equipment. Disconnect the instrument from all power sources before removing front, side or back panels and exposing potentially dangerous voltages.
- B. **DO NOT** handle exposed voltage terminations until the load and/or supply has been discharged (grounded). An unloaded supply may take up to 15 seconds to fully discharge after the instrument has been turned off and unplugged.
- C. Make sure that the actual line voltage is the proper value for which the instrument was designed. (For properly grounded outlet only).
- D. DO NOT overload the ac outlet with other electrical equipment.
- E. Adhere to the color coding descriptions when hooking up electrical connections.
- F. Repair or replace faulty or frayed wiring IMMEDIATELY when it occurs.

1.3 COMPRESSED GAS CYLINDERS

Compressed gas cylinders are potential sources of serious accidents, injuries, and even death if proper precautions and safety practices are not followed. Therefore, during handling and use of these gases, be certain to use applicable safety precautions described by your local compressed gas supplier, the Compressed Gas Association, and/or O.S.H.A. regulations.

- A. Read the label on all cylinders **BEFORE** using to identify the cylinder contents. If the label is illegible, return the cylinder to the supplier. **DO NOT ASSUME THE CONTENTS**.
- B. Secure cylinders in storage and in use to an immovable structure to prevent accidental falling or movement. Read the relevant safety codes.
- C. Store or move cylinders **ONLY** in the vertical position and with cylinder caps installed. **DO NOT** move or transport cylinders with regulators attached.
- D. Store cylinders in a well ventilated area away from heat or ignition sources.
- E. When installing tubing, provide **ONLY** approved, adequate pressure reducing regulators and pressure relief devices to prevent over-pressurizing of tubing and equipment.

- F. Never drop cylinders or permit them to strike each other violently.
- G. Cylinders may be stored in the open but, in such cases, should be protected against extremes of weather and from damp ground (to prevent rusting). In areas where extreme temperatures are prevalent, store cylinders in the shade.
- H. The valve protection cap should be left on each cylinder until cylinder has been secured against a wall or bench, or placed in a cylinder stand and is ready for use.
- I. Avoid dragging, rolling or sliding cylinders even for a short distance. Move cylinders by using a suitable hand truck.
- J. Never tamper with safety devices in valves or cylinders.
- K. Do not store full and empty cylinders together. Serious suck-back can occur when an empty cylinder is attached to a pressurized system.
- L. No part of a cylinder should be subjected to a temperature higher than 52 °C (125 °F). Do not permit flame to come in contact with any part of a compressed gas cylinder. and pressure relief devices to prevent over-pressurizing the tubing and equipment.

1.4 GENERAL

- A. Perform periodic leak checks at all fitting areas.
- B. Store organic solvents away from the GC in fireproof, vented, labeled cabinets.
- C. **DO NOT** allow flammable and/or toxic wastes to accumulate.
- D. Keep combustibles away from gas cylinders and eliminate ignition sources.
- E. **DO NOT** place papers, charts, samples, etc. on top of the GC.
- F. Maintain adequate ventilation.
- G. Dispose of wastes properly.

Chapter 2 - Specifications

The Series 400/402 Gas Chromatograph is a rugged, compact, thermal conductivity GC designed for high capability performance while withstanding rough, student or industrial use.

The flow system consists of two needle valves for accurate column flow control, dual injection ports, dual columns and exits.

Temperature of injection ports, column oven and detector oven can be individually controlled. The detector is housed in an easily accessible oven assembly. The thermal conductivity detector (TCD) contains four 32 ohm, Rhenium-tungsten (WX) hotwire filaments (standard).

The Series 400-P/402-P GC is equipped with a microscale preparative accessory system. This GC is equipped with a microscale prep detector with outlet temperature control. The system is based on the description given by Mayo, Pike, et. al., in *Microscale Organic Laboratory*, E. Wiley & Son, N. Y., 1986.

Dimensions

Overall 16.50" H (410 mm) x 12.00" W (300 mm) x 11.00" D (270 mm)

Weight 27 lbs. (12.26 kg)

Power Requirements

Series 400: 110-120 VAC, 50/60 Hz: 600 W (max), 10 A circuit breaker

Series 402: 220-240 VAC, 50/60 Hz, 600 W (max), 4 A circuit breaker

Column Oven

Dimensions: 16.19 cm H x 25.40 cm W x 18.41 cm D

Volume: 7570.67 cm³ V

Temperature Range: Ambient to 400 °C

Temperature Control: solid state, time proportioning, RTD sensors, direct reading, ambient to 400 °C

Temperature Readout: 3-1/2 digit LCD digital meter

Protection Circuit: shuts the column oven off if the temperature rises to 30 °C over set point

Detector Outlet [optional with preparative detector (Series 400-P/402-P)]

Temperature Range: Ambient to 350 °C

Temperature Control: phase control, RTD sensor, ambient to 350 °C

Temperature Readout: 3-1/2 digit LCD digital meter

Operating Temperature: 20 °C above column temperature

Oven Fittings

Accommodates 1/8" or 1/4" o.d. metal or glass columns

Oven Capacity

Two 1/4" o.d. x 12' columns or correspondingly longer lengths of 1/8" o.d.

Detector Oven

Temperature Range: Ambient to 400 °C
Temperature Control: solid state, time proportioning, RTD sensors, direct reading, ambient to 400 °C
Temperature Readout: 3-1/2 digit LCD digital meter
Operating Temperature: 15 °C higher than the column temperature

Detector

Type: Thermal Conductivity (TCD)
Design: Flow-through
Elements: Four (4) Rhenium-tungsten (WX) on standard 9225 mount, tube nut closure (standard unit)
Response Time: 0.5 seconds
Noise: 10 μ V maximum within operating parameters
Drift: 40 μ V hour maximum
Carrier Gas: Helium or Nitrogen
Max. Current Limit at ambient temp: 100 mA with He Refer to the General Service Bulletin
120 mA with N₂

Detector Power Supply

Line operated, solid state, integrated circuit regulated, constant current
55 Vdc (max.), 300 mA (max.)
Ripple and noise: < 5 mV rms

Injection Ports

Dual injection ports
Low Volume
Injection Method: direct on-column or gas sample valve injection
Septums: standard 9 mm
Operating Temperature: 0 - 400 °C
Temperature Control: solid state, time proportioning, RTD sensors, direct reading, ambient to 400 °C
Temperature Readout: 3-1/2 digit LCD digital meter

Gas Flow

Flow System: dual column with dual injection ports and exits
Flow Control: two (2) metering valves for independent flow control to each column
Filament protector pressure switch in carrier inlet line.

Thermal Conductivity Bridge Control

Polarity Switch
Bridge Zero Adjust
Current Adjustment: continuous adjustment to 300 mA (using He carrier)
Attenuator: 12 positions to 1024 plus infinity (∞)

Chapter 3 - Installation

3.1 General

The customer should read and become familiar with this section **before** proceeding with installation.

3.2 Additional Equipment Required

- A. Carrier gas cylinder with standard pressure regulator, terminating in a 1/4" or 1/8" female NPT fitting.
- B. Recording Device: a) Potentiometric recorder with 1 mV span, 1 second response; or b) a computing integrator; or c) proper computer software.
- C. Stopwatch and a 10 mL soap bubble flowmeter (GM Part No. 59-230) for gas flow measurements. A "rotameter" may be used for direct reading if it is properly calibrated using a soap bubble flowmeter. Also available is a hand-held digital bubble flowmeter, GOW-MAC Part No. 180-567 for automatic flow measurement.
- D. AC power source: Series 400: 600 W at 110 - 130 V, 50/60 Hz
Series 402: 600 W at 220 - 240 V, 50/60 Hz



Operating instructions for both series are the same, except for line voltage requirements. To prevent damage to the instrument, make sure that the AC electrical outlet is the correct voltage for your instrument BEFORE plugging it into the outlet.

- E. GOW-MAC Installation Kit (Part No. 59-400) or 1/8" o.d. clean copper tubing and Swagelok® fittings.
- F. Columns suitable to your application. The Series 400 GC comes with one (1) 20% Carbowax 20M column and one (1) 20% DC 200 column.

3.3 Unpacking-Inspection

- A. When unpacking the instrument, check it carefully for evidence of shipping damage or rough handling. Check to ensure that all components ordered have either been supplied or back-ordered. Notify the Company of any discrepancies. The packing box should be retained for use if the instrument needs to be returned to the factory for repair or modification. GOW-MAC does not supply field service. All repairs are made at our Bethlehem, PA facility or by an authorized GOW-MAC representative.

- B. Remove all plastic and/or paper shipping caps and restraints before operating.

3.4 Location

- A. The Series 400 should be placed in a location that is secure, vibration-free, and protected from abrupt temperature changes (maximum ambient temperature range is from 15 °C to 40 °C), and drafts. Such changes may upset the temperature stability in the course of an analysis or preparation.
- B. Enough adjacent tabletop space should be allowed for the installation of recorders, integrators, computers, etc. Allow sufficient space on all sides of the GC for easy access.
- C. Make sure that there is adequate space for the installation of the carrier gas cylinder. Cylinders should be securely fastened to the wall or table.



Read *Chapter 1 - Safety Precautions* to ensure proper handling of compressed gas cylinders.

- D. An electrical outlet (ac) should be near the location where the GC is to be installed. If the outlet is not a 3-pin type, make sure that a good ground is available, since a good ground is necessary for proper operation. The ac outlet should be connected to a circuit that is not heavily loaded with other electrical equipment because input voltage to the instrument should be steady for optimum operating stability.

If the ac line voltage varies, consideration should be given to the installation of a stabilizing transformer at the ac outlet.



Both recorder and GC should be connected to the same duplex service outlet to prevent ground loops.

3.5 Power Requirements

The Series 400 instrument requires a 50/60 Hz power source capable of providing up to 5 amps at 110-130 Vac.

The Series 402 instrument requires a 50/60 Hz power source capable of providing up to 3 amps at 210-230 Vac.

The ac power cord for the Series 400 is terminated with a straight-blade 3-prong plug rated for 10 amp service that requires a matching receptacle. A cord, with no plug, is supplied with the Series 402 GC.

3.6 Recorder Connection

Supplied with your GC is a recorder cable. Both ends of the recorder cable terminate in three spade terminals.

Cable color is as follows: red lead = positive (+); black lead = negative (-); and silver (shielded) lead = ground.

- A. Connect one end of the recorder cable to the terminals located at the rear of the GC (Figure 3-1). Connection should be made as follows:

Black to Black
Red to Red
Silver to Green

- B. Connect the other end of the recorder cable to the proper terminals on the recorder.

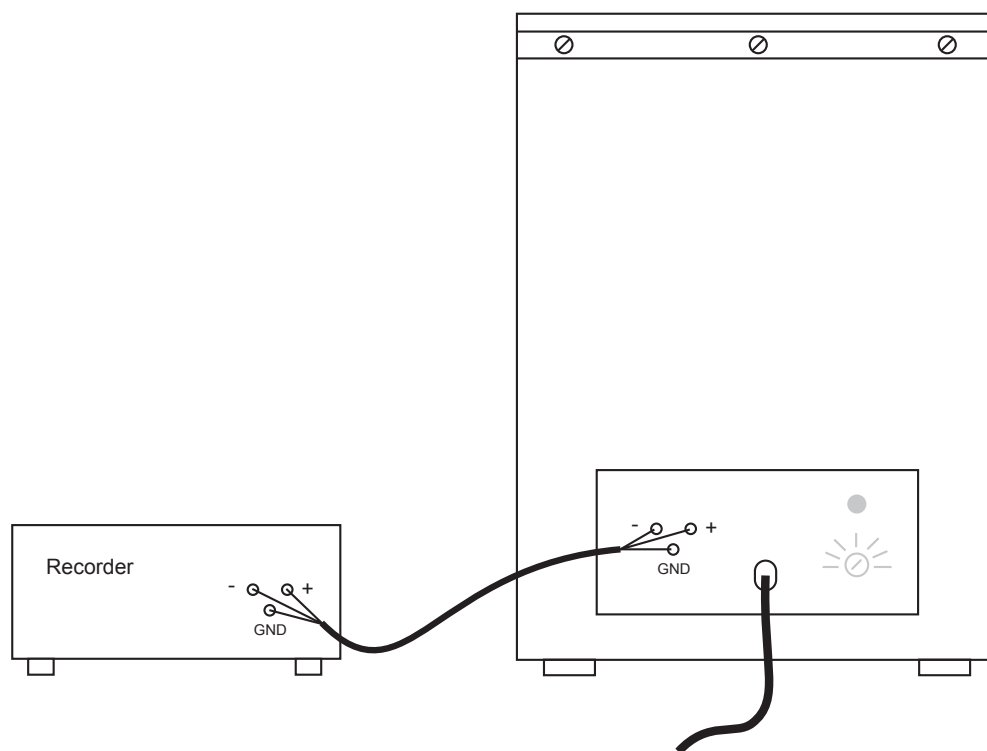

Figure 3-1
Series 400 GC and Recorder Connection



NOTE

While polarity is unimportant (because of the *Polarity Switch*), the shielded ground wire should be connected to the proper terminal on the recorder, if provided. Follow the recorder manufacturer's instructions for grounding the recorder.

3.7 Integrator Connection

The same cable referenced in the section above can be used for connecting the GC with an integrator.

3.8 Software — make reference to Chapter 7.

3.9 Gas Connections



RE-READ CHAPTER 1 - SAFETY PRECAUTIONS BEFORE CONTINUING. (O.S.H.A. REGULATION FOR THE HANDLING, STORAGE, AND USE OF COMPRESSED GAS CYLINDERS REFERS TO THE REQUIREMENTS OF THE COMPRESSED GAS ASSOCIATION, CGA).

- A. A 1/8" o.d. stainless steel tube extends from the rear of the GC (Figure 3-2). This is the **CARRIER GAS INLET**.
- B. Either using the GOW-MAC Installation Kit (Part No. 59-400) or fittings and clean copper tubing of your own, connect a 1/8" o.d. piece of copper tubing from the gas outlet located on the gas regulator of the gas cylinder to the **CARRIER GAS INLET** on the rear of the GC. (Swagelok®, Parker®, or Gyrolok® fittings are recommended).



Plastic tubing IS NOT recommended since all plastics are permeable to air.

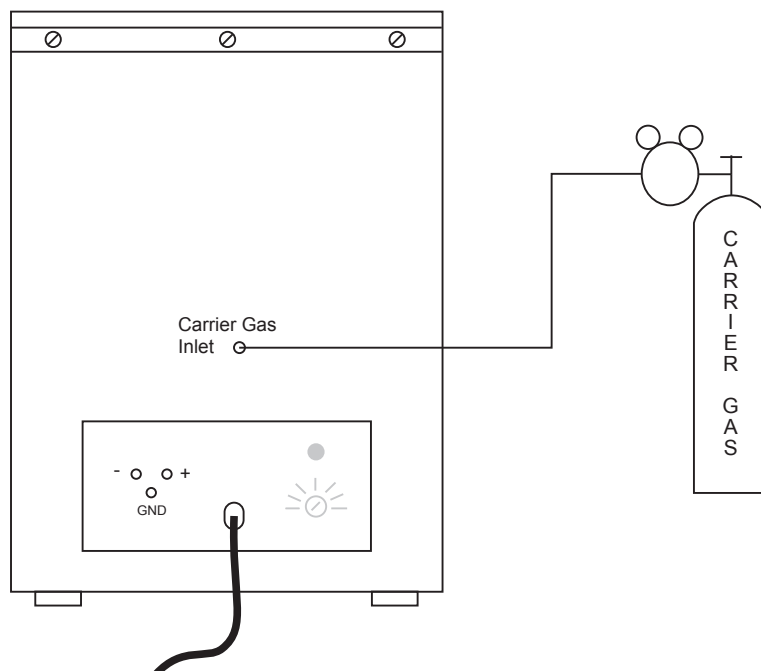

Figure 3-2
Carrier Gas Hookup (Typical)

C. To prevent contamination of your GC by grease, oil, or chemical residue, the following procedure should be followed for purging additional stainless steel or copper tubing prior to connecting it to the Series 400/402:

1. Clean tubing by flushing with acetone to remove any oil residue that may be present.
2. After washing, let tubing drain and dry.
3. Repeat Steps C-1 & C-2 three times.



ACETONE IS EXTREMELY FLAMMABLE. USE CARE WHEN USING THIS MATERIALS. DO NOT EXPOSE ACETONE TO OPEN FLAMES OR SMOKING MATERIALS. DISPOSE OF SOLVENT PROPERLY.

3.10 Leak Testing

All connections are thoroughly leak-tested prior to shipment from the factory.

A. Now that the carrier gas has been hooked up, set carrier gas flow to 30 mL/min through **BOTH** columns A and B, which flows through **BOTH** sides of the detector. Perform the following leak check procedure:

1. Open the hinged column oven cover.
2. Check all column connections (4) for tightness. The columns supplied are 1/4" o.d. and the nuts (4) require a 9/16" open-end wrench.
3. Check septum nuts on front panel for tightness (finger tight).
4. Check the carrier gas connections at the back of the GC for tightness.
5. Check the fittings at the gas cylinder and copper tubing for tightness.
6. The column flow control valves are located on the front panel of the GC (Figure 4-5). These should be closed gently (clockwise), then opened about 1/2 turn (counter clockwise).



THESE ARE PRECISION NEEDLE VALVES, NOT SHUT-OFF VALVES. CARE SHOULD BE EXERCISED IN MAKING ADJUSTMENTS.

7. If the system is leak-free, the pressure gauge should remain at 30 psig. If the pressure falls off within 15 to 20 minutes, there is a leak in the system.

8. The easiest way to locate leaks in the system is through the use of a GOW-MAC Gas Leak Detector, Series 21-080. If one is not available, the use of a leak testing solution (soap solution) and checking for bubbles may be used. Refer to Figure 3-3 to locate possible leak areas.



NOTE

STEPS 7, 8, & 9 MAY BE OMITTED IF A GOW-MAC GAS LEAK DETECTOR IS AVAILABLE.

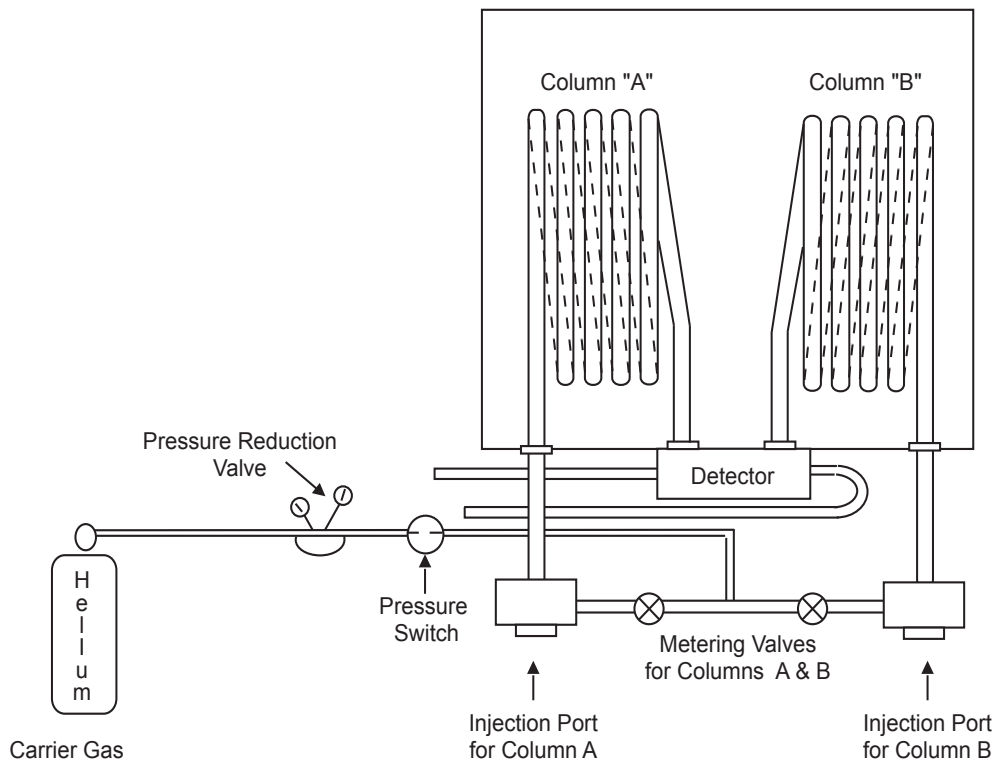

Figure 3-3



LEAK CHECKS SHOULD BE RUN PERIODICALLY AND ARE A MUST WHEN NEW COLUMNS OR CARRIER GAS FITTINGS ARE INSTALLED.

9. Once leaks have been located and stopped, return the instrument to operating condition; bleed all pressurized lines to atmospheric pressure, remove Tygon® tubing at **OUTLET PORTS**.

3.11 Gas Flow Adjustments



Inert carrier gas **MUST** be flowing through **both columns A and B as well as sides A & B** of the TC detector. **THIS IS EXTREMELY IMPORTANT and NECESSARY to preserve the filaments!**

Failure to set flow rates on both sides causes oxidation and destruction of the filaments in the presence of oxygen.

A bubble type flowmeter attached to a stand should be connected to **OUTLET PORT "A"** by means of a flexible tube (Figure 3-4). Fill the reservoir of the meter with a 2 - 3% liquid soap or detergent solution. A stopwatch is recommended for the flow measurement. Proceed as follows:

- A. Gently squeeze the reservoir of the flowmeter until a stream of soap bubbles emerge. Allow the soap bubbles to rise and wet the sides of the glass meter. *START* the stop watch when a soap bubble reaches the "0" mark on the meter. *STOP* the stopwatch when the soap bubble reaches the "10" mark on the meter. The elapsed time, in seconds, for the soap bubble to rise from "0" to "10" mL divided into 600 equals the flow rate in mL/min. Adjust **SIDE "A" FLOW CONTROL VALVE** for the desired flow rate (about 60 mL/min.).

$$\frac{600}{\text{sec}} = \text{flow rate}$$



Before each measurement, allow one minute or so for the flow rate to equilibrate after each adjustment.

- B. Change the flowmeter to **SIDE "B" OUTLET PORT** and adjust column "B" for the same flow rate (about 60 mL/min)
- C. The flow rates have now been adjusted. Disconnect the flowmeter.

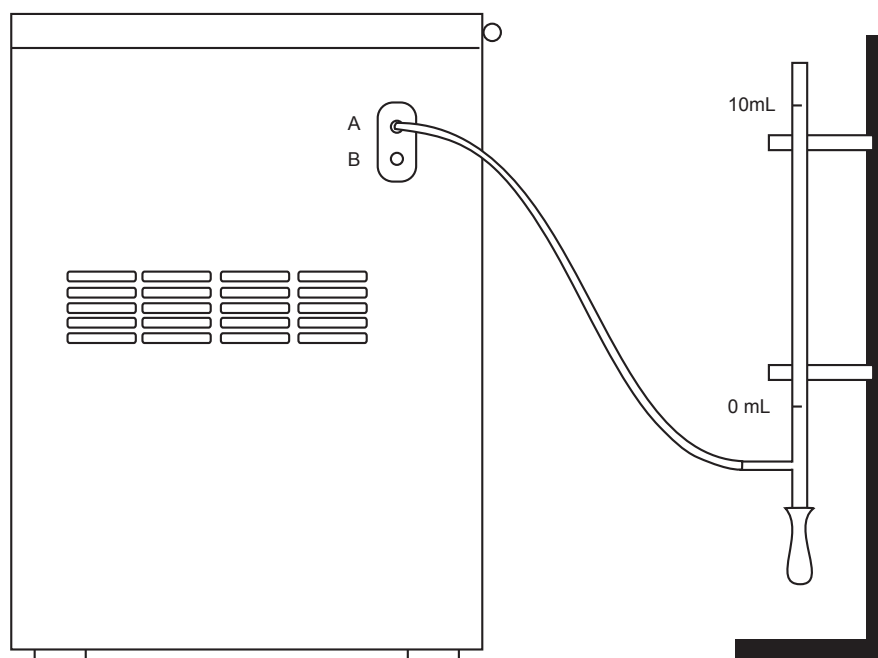

Figure 3-4
Flowmeter Measurement

3.11 Installation Check List

A. Electrical

- Correct voltage and frequency
- Interconnecting cables to additional instruments installed
- Power **OFF**

B. Pneumatic

- Required gas supplies hooked up
- Carrier gas flowing through **BOTH** columns and detector
- Cylinders chained or strapped to wall or bench
- Regulators set for suggested delivery pressure (20-30 psig)
- Connecting lines and fittings leak checked
- Flow rates checked and adjusted

Chapter 4 - Operation

4.1 Controls

- A. All operating controls of the Series 400 GC are located on the front panel. The operator should become familiar with these controls and their functions before continuing. Refer to Figure 4-1.

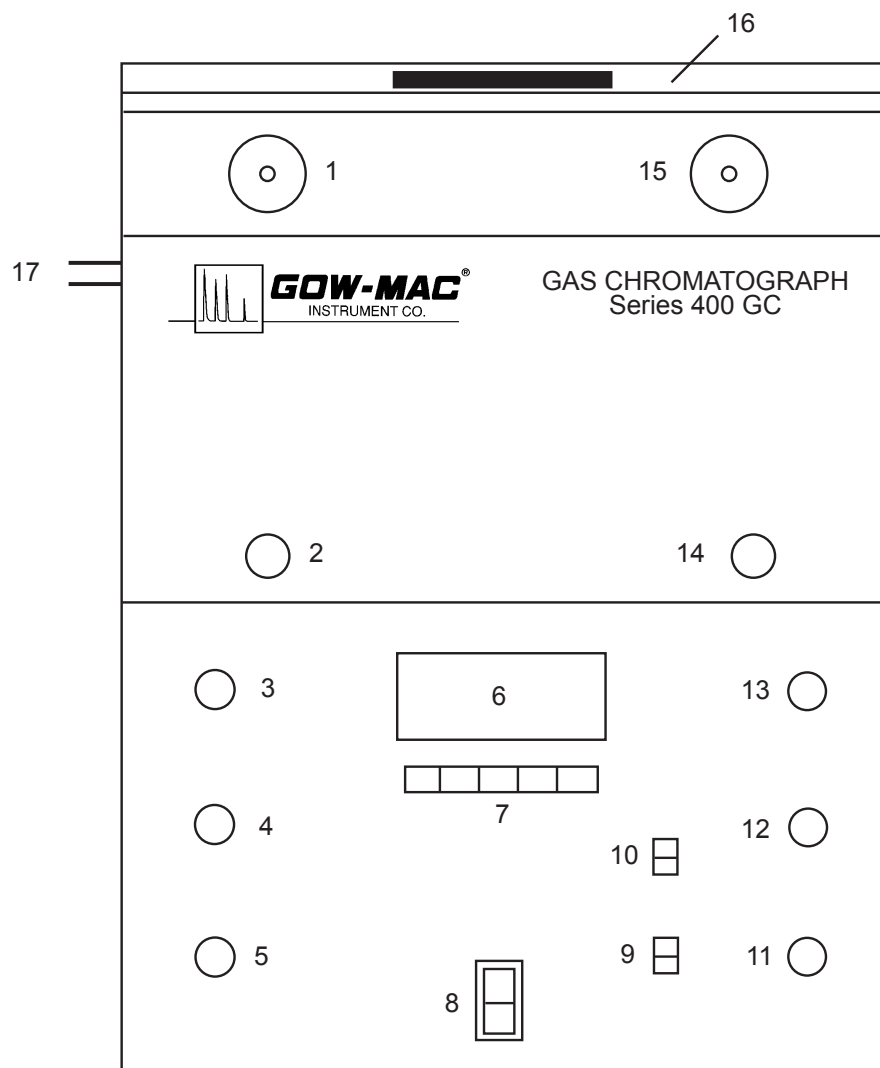

Figure 4-1
Front Panel - Controls

- | | |
|---------------------------------|-----------------------------|
| 1. Injection Port "A" | 10. Detector Current Switch |
| 2. Flow Adjustment "A" | 11. Zero Control |
| 3. Column Temp. Control | 12. Attenuator |
| 4. Detector Temp. Control | 13. Bridge Current Control |
| 5. Injection Port Temp. Control | 14. Flow Adjustment "B" |
| 6. Digital Panel Meter | 15. Injection Port "B" |
| 7. Selector Buttons | 16. Column Oven Lid |
| 8. GC Power Switch | 17. Exit Ports A & B |
| 9. Polarity Switch | |

1. **INJECTION PORT "A"**
2. **FLOW ADJUSTMENT "A"**
3. **COLUMN TEMPERATURE CONTROL:** Selects the isothermal temperature of the column oven. The temperature may be monitored on the **DIGITAL PANEL METER** when the COL. TEMP. Button is pressed (see 7b below). Knob is "locking type". Push locking ring "in" to turn knob.
4. **DETECTOR TEMPERATURE CONTROL:** Selects the temperature of the detector oven. The temperature may be monitored on the **DIGITAL PANEL METER** when the DET. TEMP. Button is pressed (see 7c below). Knob is "locking type". Push locking ring "in" to turn knob.
5. **INJECTION PORT TEMPERATURE CONTROL:** Selects the temperature of the injection ports. The temperature may be monitored on the **DIGITAL PANEL METER** when the INJ. PORT. TEMP. Button is pressed (see 7a below). Knob is "locking type". Push locking ring "in" to turn knob.
6. **DIGITAL PANEL METER:** Displays the value of the operation function chosen by the SELECTOR BUTTONS.
7. **SELECTOR BUTTONS:**
 - a. INJECTION PORT TEMPERATURE (°C): selects injection port temperature to appear on the DIGITAL PANEL METER.
 - b. COLUMN OVEN TEMPERATURE (°C): selects column temperature reading to appear on the DIGITAL PANEL METER.
 - c. DETECTOR TEMPERATURE (°C): selects detector temperature reading to appear on the DIGITAL PANEL METER.
 - d. DETECTOR CURRENT: selects detector current reading to appear on the DIGITAL PANEL METER.
 - e. SET (IN)/ACTUAL (OUT): selects either actual or set-point parameters for any of the functions (a-d) above. This button should be left in the "ACTUAL" (OUT) position **EXCEPT** when settings are being changed.
8. **GC POWER SWITCH:** Supplies line power to the GC when depressed and lit.
9. **POLARITY SWITCH:** Selects polarity (+/-) of the detector output signal. Allows use of each column without having to change the wiring to reverse polarity on the recorder.
10. **DETECTOR CURRENT SWITCH:** allows the detector to be turned ON/OFF without shutting down the entire instrument.
11. **ZERO CONTROL:** Adjusts the detector output level for zeroing the baseline of the recorder. Recorder should be zeroed first with short input.

12. **ATTENUATOR:** Twelve step to 1024 plus infinity, in multiples of 2. Increases or decreases the size of the peaks obtained by attenuating the output of the bridge current. A setting of "1" indicates maximum sensitivity.
13. **DETECTOR CURRENT CONTROL:** determines the sensitivity of the instrument. The higher the current, the more sensitive the instrument becomes. Chart 4-1 illustrates the maximum current for specific cell temperature. **THE MAXIMUM CURRENT SHOULD NOT BE EXCEEDED!** For longer filament life and a stable baseline, lower filament temperatures are recommended. Recommended starting bridge setting is 100 mA for helium carrier gas.
14. **FLOW ADJUSTMENT "B"**
15. **INJECTION PORT "B"**
16. **COLUMN OVEN LID**
17. **EXIT PORTS "A" & "B"**
18. **COLUMNS**

The oven is designed to accept twelve (12) feet of 1/4" tubing. Correspondingly longer lengths of 1/8" tubing can be wound on a mandrel of 4" o.d. Columns of 1/8" o.d. with 1/4" ends can be ordered from GOW-MAC. Figure 4-2 illustrates columns "A" & "B". An appropriate column or bypass must be installed in both "A" and "B" sides or damage will result to the detector.

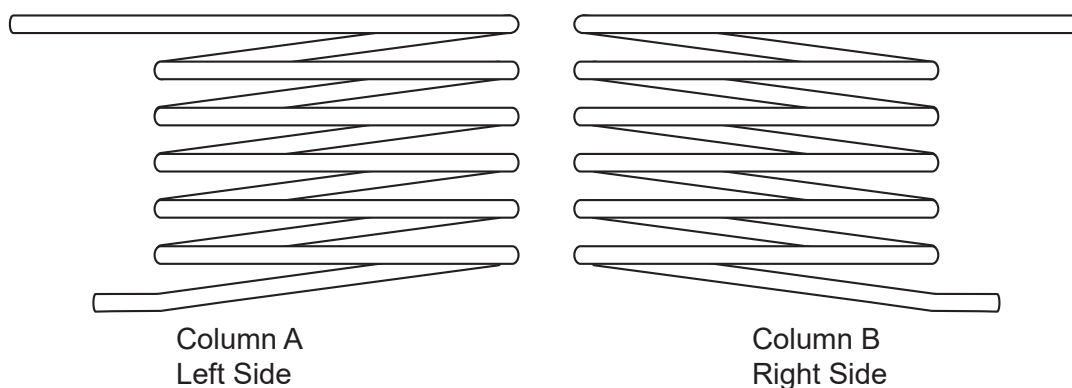

Figure 4-2
Columns

4.2 Initial Test Warmup

The chromatographer should be familiar with the techniques of chromatography, the function of all controls, the operation of the recording device, and the characteristics of the columns used prior to running samples.

A. Gas Flow



Inert carrier gas **MUST** be flowing through **both columns A and B as well as sides A & B** of the TC detector. **THIS IS EXTREMELY IMPORTANT and NECESSARY to preserve the filaments!**

Failure to set flow rates on both sides causes oxidation and destruction of the filaments in the presence of oxygen.

1. Make sure that **ALL** switches are in the **OFF** position.
2. Set helium (or other carrier gas) pressure regulator to 40 psig. A minimum of 20 psig is necessary.
3. Adjust carrier gas to: 30 mL/min. for 1/8" columns
 60 mL/min. for 1/4" columns
4. Check for leaks as described in Chapter 3.
5. Disconnect flowmeter.
6. Allow 5 minutes to purge the system before turning power **ON**.

B. Temperature Controls



TEMPERATURE CONTROL KNOBS are locking type.
Push locking ring "IN" to turn knob.

1. **ALL** switches should be in the **OFF** position.
2. Turn **DETECTOR CURRENT CONTROL** fully counterclockwise (CCW). **THIS STEP IS EXTREMELY IMPORTANT!**
3. Plug in the GC to the appropriate ac outlet. Switch the instrument ON (**HELIUM MUST BE FLOWING!**).
4. Set **INJECTION TEMPERATURE CONTROL** to desired setting.
5. Set **COLUMN TEMPERATURE CONTROL** to desired setting.
6. Set **DETECTOR TEMPERATURE CONTROL** to desired setting.

Chart 4-1 illustrates the maximum currents for cell temperatures and carrier gases helium, nitrogen, and argon.

THESE SHOULD NOT BE EXCEEDED! For longer filament life and a stable baseline, lower filament temperatures are recommended. Recommended starting bridge setting is 100mA for helium carrier gas.

Example: A setting of 200 on the DET. TEMP. CONTROL results in an operating temperature of 200 °C, thus maximum bridge current when using **helium** at this temperature is 240 mA. **When maximum sensitivity is not required, the current should be reduced to 100 mA.**

W, WX, W2, W2X, AuW, AuW2, Ni, Ni2 Type Filaments

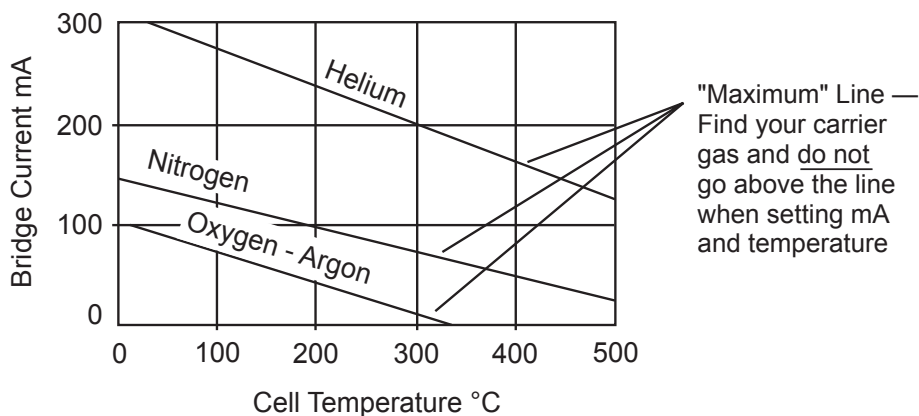

Chart 4-1

7. After 20-30 minutes, press the **SELECTOR BUTTON** for **BRIDGE CURRENT**.
8. Turn the **DETECTOR CURRENT SWITCH** to **ON**.
9. Adjust the **BRIDGE CURRENT CONTROL** to the desired setting (refer to CHART 4-1).



NOTE

IF BRIDGE CURRENT DOES NOT RESPOND, CHECK CARRIER GAS PRESSURE. THE FILAMENT PROTECTOR SWITCH MUST HAVE 15-20 PSIG TO OPERATE.

After approximately 45-60 minutes, the instrument should be up to temperature and ready for the injection of samples. During the warm-up period, recording devices should be zeroed.

4.3 Strip Chart Recorder

The Series 400 GC is suitable for use with almost any strip chart recorder of the potentiometric type (1 mV, 10 mV, or other). For best results and maximum sensitivity, the 0 - 1 mV is recommended. An adjustable chart drive is also recommended: 1/4, 1/2, 1, 2 in/min.

- A. Connect the recorder to the GC.

- B. Turn the strip chart recorder **ON**.
- C. Adjust the **GC ATTENUATOR** to infinity (∞).
- D. Adjust the **RECORDER ZERO KNOB** to position the pen to the desired baseline on the strip chart usually 5 to 10 small divisions on the chart paper). Where positive and negative peaks are expected, the pen may be set mid-scale. If the pen response is slow, the recorder may require adjustment (Refer to the recorder operating manual).
- E. Set the **GC ATTENUATOR** to the "64".
- F. Adjust the **GC ZERO CONTROL** to reposition the pen to the same spot located in Step D above. When zeroed, the attenuator may be switched to any setting and the pen should not move. The **POLARITY SWITCH** should be set so that the drift due to GC warm-up is upscale. In this manner, the extent of drift and the leveling out of the baseline may be observed.

Baseline drift may continue if the oven or ambient temperature continues to change (2 to 4 hours). Let the GC warm up a little longer. If drift continues after 5 to 6 hours, check for leaks in the system.

- G. Refer to the recorder manual for correct chart speeds, warm-up times, etc.

4.4 Computer Integrator Zeroing

The Series 400 GC may also be used with commercially available computing integrators.

After the integrator is properly connected to the instrument, it may be turned "ON". At this time the electrical or recorder zero should be established and reference should be made to the integrator operating manual for further operating instructions.

4.5 Chromatography Data Software

The Series 400 GC may also be used with most commercially available chromatography data software.

GOW-MAC offers a chromatography data software program called *Clarity*®. This software enables the customer to directly control the data coming from the GC on a personal computer. If *Clarity*® is being used in conjunction with the Series 400, follow the setup instructions that come with the software.

4.6 Sampling Procedure

Once the instrument has been brought to the desired temperatures and the recording device has been lined out, the following may be done:

- A. Change the **GC ATTENUATOR** to a setting of "8", then "4", etc. until a straight-line trace is obtained at the selected temperature.
- B. *INJECT* the sample.

- C. Observe the chromatograms for peak separations, peak heights, and retention times. Adjust controls accordingly.

4.7 Standby and Overnight Conditions

When the GC is used intermittently during the day or is needed right away the next morning, it is recommended that the GC be kept in "standby" condition. This keeps the instrument ready to use without waiting for a long equilibration period. Proceed as follows:

- A. Push the **SET** Button and **DETECTOR** Button "IN".
- B. Turn **DETECTOR CURRENT CONTROL** counterclockwise (CCW) until the **DIGITAL PANEL METER** displays between 28 to 40. Then turn **CURRENT SWITCH** to "off" position.
- C. Reduce the carrier gas flow from 40 psig to 20 psig to save gas consumption (**FLOW RATE MUST NOT FALL BELOW 20 psig**).

4.8 Shutdown Procedure

The following sequence of steps should be followed in the given sequence to insure proper cool-down of your GC and longer life of the detector filaments.

- A. Push the **SET** and **DETECTOR CURRENT** Buttons "IN".
- B. Turn the **DETECTOR CURRENT CONTROL** counterclockwise until the **DIGITAL PANEL METER** displays between 28 to 40. Then turn the **CURRENT SWITCH** to "off" position.
- C. Repeat Steps A & B above for the **COLUMN, DETECTOR, and INJECTOR**.
- D. Let the GC cool down for 30 minutes. For quicker oven cool down, the column oven lid may be lifted and left open.
- E. Let the GC cool down until the detector temperature reaches 90 °C. **The filaments may burn out if the instrument is not left to cool properly.**



**IF THE INSTRUMENT IS NOT LEFT TO COOL PROPERLY,
THE DETECTOR FILAMENTS MAY BURN OUT (OXIDIZE).**

- F. Elute all samples from the column **BEFORE** the columns cool down.
- G. Shut ac power **OFF**.
- H. Turn helium or other carrier gas "OFF".



IT IS MOST IMPORTANT THAT ELECTRICAL POWER BE TURNED OFF BEFORE THE HELIUM IS TURNED OFF. AS LONG AS THE CELL AND FILAMENTS ARE HOT, THE HELIUM SHOULD BE FLOWING THOUGH THE DETECTOR. THE FLOW RATE CAN BE REDUCED TO CONSERVE HELIUM.

4.9 Daily Setup Check List

It is good practice to check the following items at the beginning of each day or shift, and when starting up the GC after a weekend shutdown.

A. Electrical

_____ Additional instrumentation is connect properly.

B. Pneumatic

_____ Gas cylinder pressure is sufficient.

_____ Cylinder pressure regulator set properly.

_____ Gas flow rates are adjusted properly.

_____ Appropriate columns are installed.

_____ Leak check.

C. Front Panel

_____ All temperature setting controls are set *BELOW* the recommended circuitry maximum limits (Chart 4-1).

_____ Recording device zeroed.

_____ Detector filaments are **ON (CARRIER GAS MUST BE FLOWING THROUGH BOTH SIDES OF THE DETECTOR).**

Chapter 5 - Microscale Prep

5.1 The Microscale Preparative GC Collection System (Series 400-P/402-P w/ P/N 59-425)

- A. The Microscale Preparatory Collection System consists of five major components: (1) a temperature control unit, (2) a stainless steel adapter with 6-32 NPT female threads for connection to the heated, threaded exit port and found to accept a male 5/5 joint; (3) two collection tubes possessing a 5/5; (4) two 100 mL conical vials with threaded neck ground to a 5/5, and (5) a special detector with threaded/heated exit ports.

Preparative columns (included when P/N 59-425 is ordered) consist of one each of a) 8' x 1/4" 20% Carbowax 20M on Chrom P, 80/100 mesh and b) 8' x 1/4" DC-710 on Chrom P, 80/100 mesh.

B. Temperature Control

1. The temperature of the heated exit ports is achieved with a separate control unit mounted on the rear of the GC (Fig. 5-1). Included in the temperature control unit are:
 - a. Dial to set the exit port temperature.
 - b. Momentary switch for temperature readout.
2. Setting Exit Port Temperature
 - a. Set the **SET/ACTUAL** button located on the Panel Meter to ACTUAL.
 - b. Push selector button **DETECTOR** of the Panel Meter. Push and hold the **MOMENTARY SWITCH** on the rear of the GC to read the temperature.

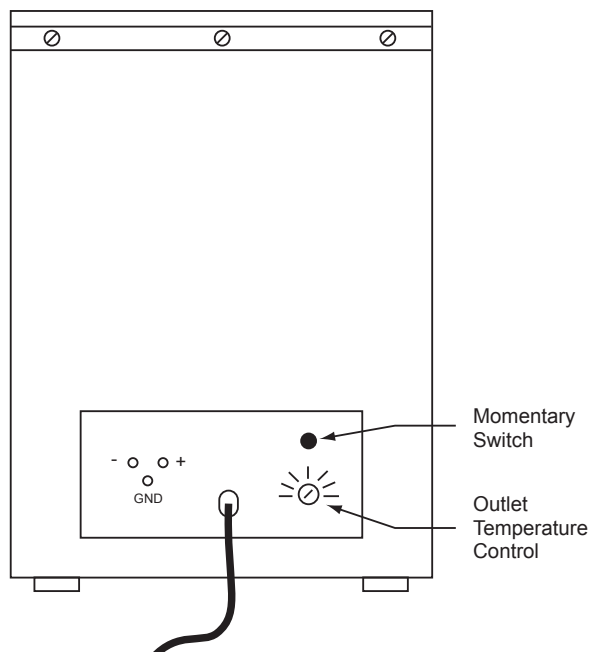

Figure 5-1

- c. Using Chart 5-1 and some experimentation, adjust the phase control knob located on the rear of the GC until the desired exit port temperature is achieved.



Phase control is not direct temperature setting and temperature should be determined by experimentation. For example, a dial setting of 40 does not indicate a temperature of 40 °C.

- d. Press and hold the momentary switch located on the back of the GC to indicate the temperature of the exit port, read on the Panel Meter.

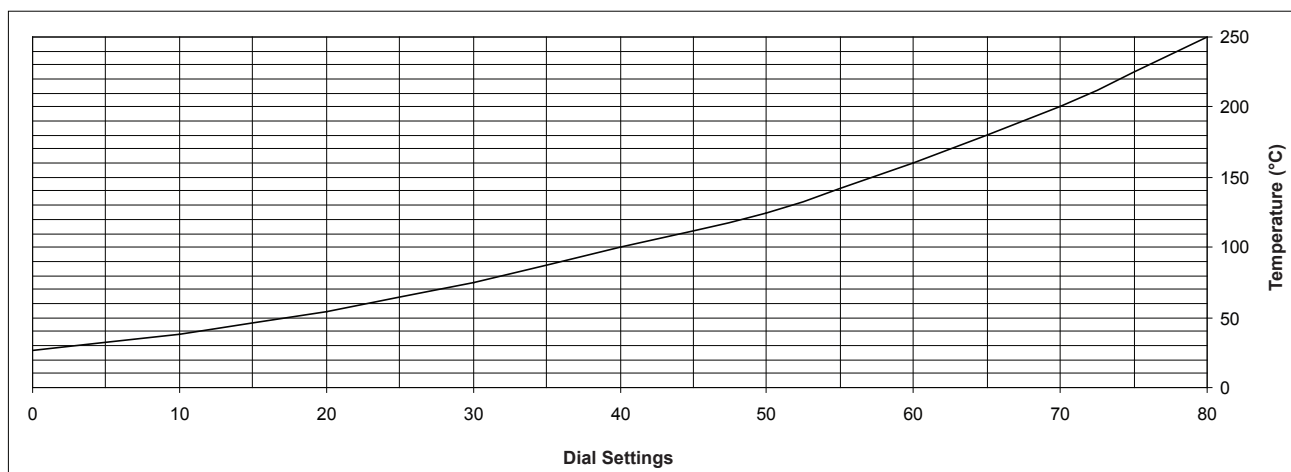

Chart 5-1
Exit Port Temperature Settings

Graph represents average dial and temperature settings. Your readings will vary. We suggest plotting your own instrument's curve on the above curve for easy and accurate reference. Allow three hours between dial setting changes for temperature to stabilize before plotting temperature.

C. Procedure

1. Attach the adapter to either column "A" or column "B" exit port of the GC. Which exit port is determined by which column the analysis is being performed on. If not using the adapter supplied in GOW-MAC's Microscale Prep Kit, P/N 59-425, make sure the adapter has 6-32 NPT threads.



IT IS MOST IMPORTANT THAT THE ADAPTER BE THREADED ONTO THE EXIT PORT COMPLETELY. THE END OF THE EXIT PORT MUST EXTEND WELL INTO THE GROUND STANDARD TAPERED PART OF THE ADAPTER WHEN IT IS ATTACHED TO THE EXIT PORT. THIS ARRANGEMENT WILL ALLOW THE END OF THE EXIT PORT TO BUTT SNUGLY AGAINST THE COLLECTION TUBE WHEN FULLY ASSEMBLED. IT IS ABSOLUTELY ESSENTIAL THAT THIS CONTACT IS MADE.

2. When the recorder indicates that the fraction to be collected is approaching the end of the column, the collection tube (previously cleaned and oven dried) is seated in to the adapter.
3. Place a collection tube into the adapter by rotating the collection tube while inserting it into the adapter. If too much pressure is applied the collection tube will unseat. It is important to practice rotating the collection tube **GENTLY** to obtain just enough pressure to make a good seal, but not enough to unseat the joint.
4. The preparative GC fraction is now collected as it passes through the exit port into the collection tube. Efficient collection is facilitated (diminished aerosol formation) by the large heat sink afforded by the mass of the stainless steel adapter. Once the recorder indicates that the fraction is off the column, the collection tube should be detached from the adapter.
5. The collection tube should then be connected to a tared 100 μ L conical vial and placed in a centrifuge tube (cotton padding around the collection tube and bottom of the vial is recommended - refer to Figure 5-2). Centrifuge the assembly. The collected GC fraction has now been collected. Detach the vial from the collection tube, cap the vial and weight it.

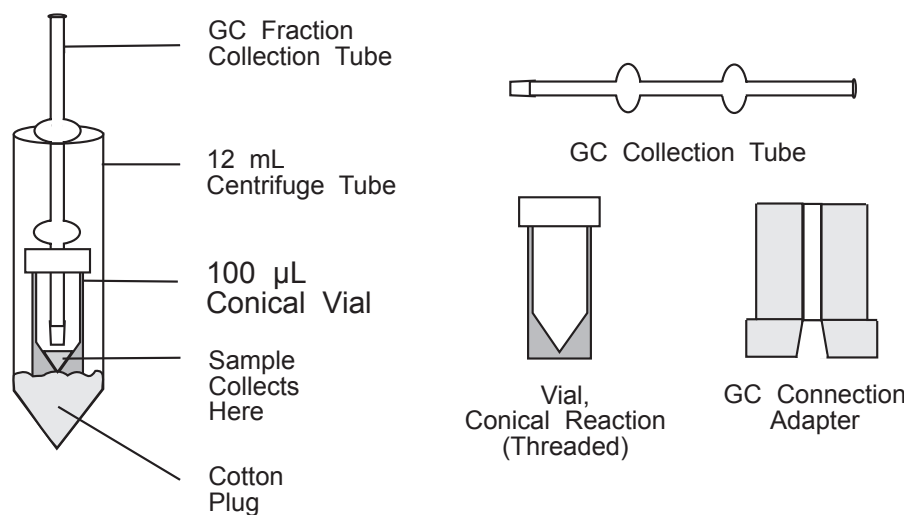

Figure 5-2
Microscale Prep Glassware

Chapter 6 - Valves

6.1 Valves

If your GC is not equipped with Gas Sample Valves, proceed to the next chapter.

- A. All valves must be treated with **CARE**. Foreign materials such as metal filings or abrasive particles can permanently damage the sliders of the valves. GOW-MAC recommends 2-micron particle filtration of gases connected to the gas sample valves.



VALVES HAVE UPPER TEMPERATURE LIMITS WHICH, IF EXCEEDED, CAN PERMANENTLY DAMAGE SLIDERS. GOW-MAC USES VALCO VALVES IN ALL OUR GCs. THESE VALVES USE SLIDERS OF FILLED TEFLON® AND HAVE AN UPPER TEMPERATURE OF 175 °C OR 300 °C. DO NOT EXCEED THESE TEMPERATURES.

UPPER TEMPERATURE LIMITS:

VALCO LOW TEMPERATURE VALVES: 175° C

VALCO HIGH TEMPERATURE VALVES: 300 °C

6.2 Valves and Their Functions

Valves are used to accomplish two basic operations in gas chromatography. One is inject a sample onto the head of the GC column and the other, to reroute or "switch" the flow of the carrier gas or sample stream.

Within the broad category of switching there are many valve functions, i.e., back-flushing, detector switching or column selection.

Although most valves are categorized as either sampling or switching, some valves combine both functions and are termed "multifunction" valves.

6.3 Sampling Corrosive Materials

When dealing with harsh samples, such as chlorine and wet acid gases, valves made of Hastelloy C-276 are recommended.

Corrosion Resistance of Hastelloy to Some Common Chemicals

Excellent

Acetic Acid
Amines
Ammonia
Chlorine (dry)
Formic Acid
Hydrogen Chloride (dry)
Hydrogen Sulfide
Phosgene
Sulfur Dioxide

Slow Attack

Bromine Gas
Chlorine (wet)
Hydrochloric Acid
Nitric Acid
Phosphoric Acid

Not Recommended

Fluorine
Hydrofluoric Acid
Hydrofluoride

6.4 Gas Sample Valve

The gas sample valve is used to introduce gas samples into the chromatograph on a reproducible basis. The sample may be taken from a static system or from a flowing system. Valves are also used for column back-flush, column selection, sample selection and detector switching.

Since the most common use of the valve is for sample introduction, only that application will be discussed here in general terms. The valve may be installed in place of, or in series with the injection port. The valve may be permanently connected to a sample source or the sample may be passed through by means of a pump or other sample container.

The size of the sample loop is fixed but can be easily changed (see below).

The valve is first placed in the counter clockwise (CCW) position, that is, the valve handle is as far counter clockwise as it will go. At this time, the sample is purged through the loop and the carrier gas merely passes through the valve to the column. When the valve handle is placed in the clockwise (CW) position, the carrier gas purges the sample from the loop and carrier it through the column. The valve is then returned to the CCW position.



The sample is released to atmosphere in either valve position.

Care must be exercised to allow sufficient time for the sample loop to be filled with the sample before injection. This is easily calculated from the carrier gas flow and size of the sample loop. The same holds true for time allowed for the sample to enter the column.

6.5 Sample Loops

A. Sizes

Sampling valves are supplied with a 2 mL loop if not otherwise specified on the order. Other sample loops are available, including: 0.25 mL, 0.50 mL, 1.0 mL, 2.0 mL, 3.0 mL, 4.0 mL, 5.0 mL, 10.0 mL, and 20.0 mL.

B. Procedure for Removing and Replacing Loops

1. Unscrew loop mounting fittings (2) and remove loop.
2. Insert new loop and tighten fittings.

6.6 Pneumatically Actuated Valves

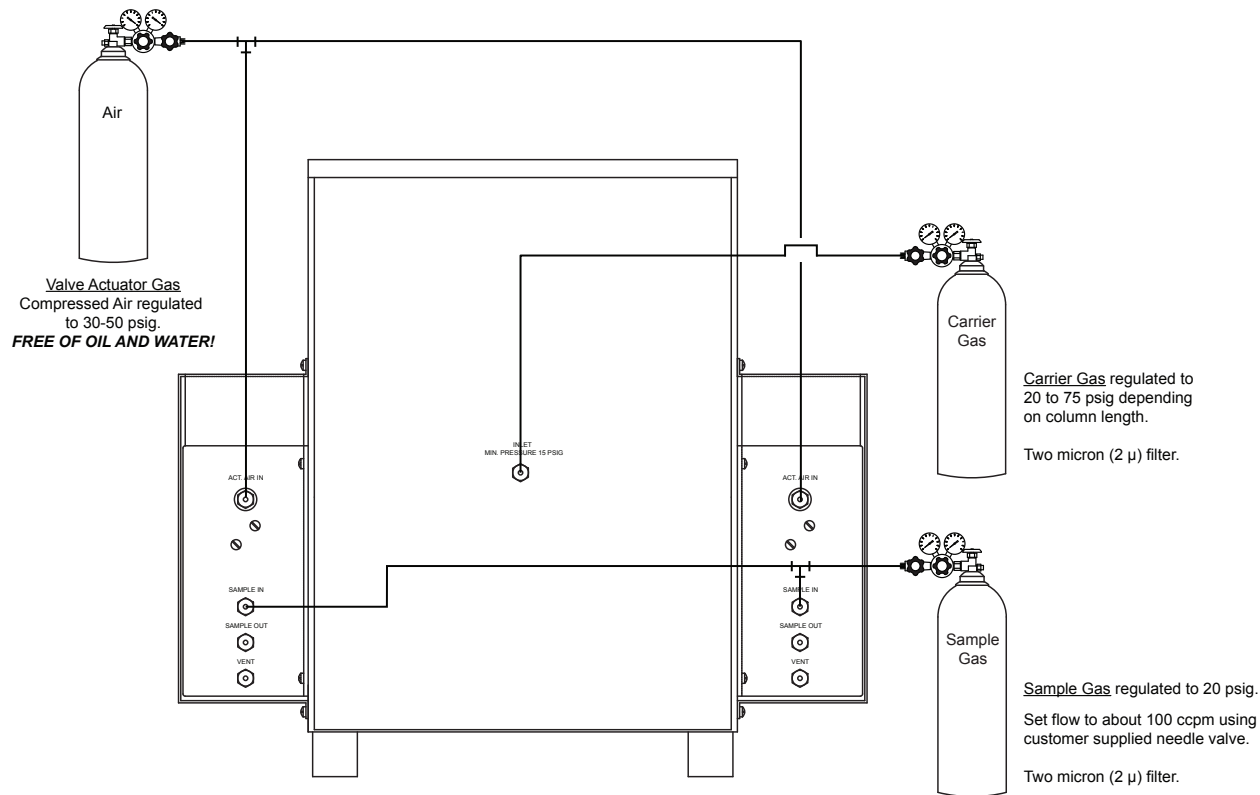
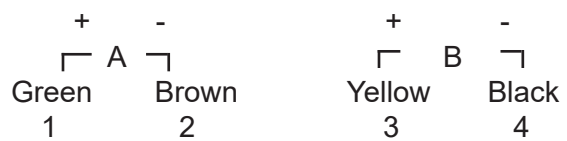

Figure 6-1: Typical Setup. Your's may vary. Refer to enclosed flow diagram.

- A. Pneumatically actuated gas sample valves require compressed air gas that is **free of oil and water** to function. An air pressure of 30-50 psi is recommended to fully drive the valves.
- B. A TTL Interface PCB enables the operator to control the pneumatic actuated valves that are installed in the GC via an external controller, i.e., computing software or computing integrator.

This external controller must be able to supply an active high (+5 V) TTL signal to the corresponding Valve Actuator (TTL) Cable Connection located on the GC's Valve Housing. This +5 V signal must be kept "ON" for the entire period of time the user wants to keep the valve(s) actuated.

- C. Connect the Interface Cable provided to the VALVE ACTUATORS Terminal Strip located on the back of the *Valve Housing(s)*. Moving top to bottom along the strip, attach the color coded wires in the following sequence:



- D. Refer to the External Control Option in the software operating manual for complete installation/operating instructions.



Make sure that power is *not* applied to any of the instrumentation until *all* electrical connections have been made between *all* devices.

The power cords to the instruments must be connected *only* to a line power source with a protective earth ground.

Both the recording device and the GC should be connected to the same duplex service outlet to prevent ground loops.

The source voltage must be within the specification of each device and/or instrument. Check the requirements for each device or instrument in their respective manuals.

GOW-MAC GCs can be set up many different ways to acquire and control the data produced by the GC. These setups can range from being completely manual, to almost fully automated with the proper devices. Signal output from the GC is a voltage level ranging from 0-1 volt, or 0-10 volts. The full description and function of the external cables are discussed earlier in this chapter. When connecting the GC to an integration device, please refer to the manual for that device for proper interfacing connections.



Check all input and output specifications of instruments and other devices to be used in order to ensure that the connections to the GC are compatible. If there is uncertainty please call GOW - MAC's Technical Support Team at (610) 954-9000.



Go to the Data Apex website (www.dataapex.com) and register your software. After you register your software go to Downloads - Documentation - Manuals. Then find "Clarity Getting Started" for help on how to hook up your instrument.



THE INSTRUMENT CAN BE DAMAGED IF IMPROPER CONNECTIONS ARE MADE.

7.1 Set Up

Unpack and set up the Gas Chromatograph as per the instructions outlined in this Operating Manual.

Using the Operating Manual provided with your software, unpack, install, and configure the interface device.

Chapter 8 - Experimental Run

8.1 Introduction

Since one of the purposes of the Series 400 GC is its use as an instructional instrument, this chapter will, in general, run through a typical experiment.

The sample to be chromatographed is a mixture of *n*-heptane, tetrahydrofuran (THF), 2-butanone, and *n*-propanol in about equal parts. Such a mixture should be prepared.

8.2 Columns Needed

Column A: 4' x 1/8" 20% Carbowax 20M on Chromasorb P AW DMCS, 80/100 mesh
Column B: 4' x 1/8" 20% DC-200 on Chromasorb P AW DMCS, 80/100 mesh



If other columns are to be used, corresponding column and injection port operating temperatures should be determined.

8.3 Gas Flow



Inert carrier gas **MUST** be flowing through **both columns A and B as well as sides A & B** of the TC detector. **THIS IS EXTREMELY IMPORTANT and NECESSARY to preserve the filaments!**

Failure to set flow rates on both sides causes oxidation and destruction of the filaments in the presence of oxygen.

- A. POWER SWITCH "**OFF**".
- B. Turn Helium "**ON**".
- C. Check for leaks as described in Chapter 3.
- D. Adjust flow to 80 mL/min in each column. Make sure to check flow for **BOTH** columns by using the flow meter at the exit ports..
- E. Disconnect flowmeter.

8.4 Electrical

- A. **DETECTOR CURRENT SWITCH "OFF"**.
- B. **BRIDGE CURRENT CONTROL** fully counterclockwise (CCW).

- C. **GC POWER SWITCH "ON"**.
- D. **INJECTION PORT TEMPERATURE CONTROL** to 130-135 °C (10-15 °C higher than the column oven temperature).
- E. **COLUMN TEMPERATURE CONTROL** to 120 °C.
- F. **DETECTOR TEMPERATURE CONTROL** to 130-135 °C (10-15 °C higher than the column oven temperature).



THE DETECTOR MUST BE KEPT APPROXIMATELY 10-15 °C HIGHER THAN THE COLUMN OVEN TEMPERATURE TO AVOID CONDENSATION AND CONTAMINATION OF THE TCD.

- G. Allow the GC to come to temperature, about 40 minutes.
- H. After the GC has warmed up, press the **SELECTOR Button** for **BRIDGE CURRENT**.
- I. Turn the **DETECTOR CURRENT SWITCH** to **ON**.
- J. Adjust the **CURRENT CONTROL** to 100 mA.
- K. Turn the recorder **ON**.
- L. Zero the recorder (Chapter 4). If a peak goes off scale, the **ATTENUATOR** should be turned to a position that brings the peak back on scale.
- M. Set **POLARITY SWITCH** for an upscale drift.

8.5 Procedure

- A. Temperatures required for this experiment are 130 °C on the **DETECTOR** and 120 °C on the **COLUMNS**. The **INJECTION PORT TEMPERATURE** should be approximately 10-15 °C higher than the column temperature.
- B. Set the **POLARITY SWITCH** to the Carbowax column. Put the **ATTENUATOR** on "1". When the temperatures have reached the desired settings and the baseline of the recorder has lined out you are ready to make an injection.
- C. Draw a 1 µL **SAMPLE** into the syringe and then draw about 5 µL of air. With the recorder running (1"/min. or faster), inject the sample onto the Carbowax column.



The injection ports are designed for on-column injection. When injecting the sample, insert the needle through the septum approximately one (1) inch. Depress the plunger of the syringes to inject the sample.

- D. Mark the point of injection on the chart paper as well as the other pertinent information about this sample. The first (small) peak to be eluted is the air peak and it will be followed by the 4 components of the mixture in the order listed in Table 8-1. You can verify the identity of each peak by running small samples of each liquid individually. Note the reproducibility of the retention times. A typical chromatogram is shown in Figure 8-1.

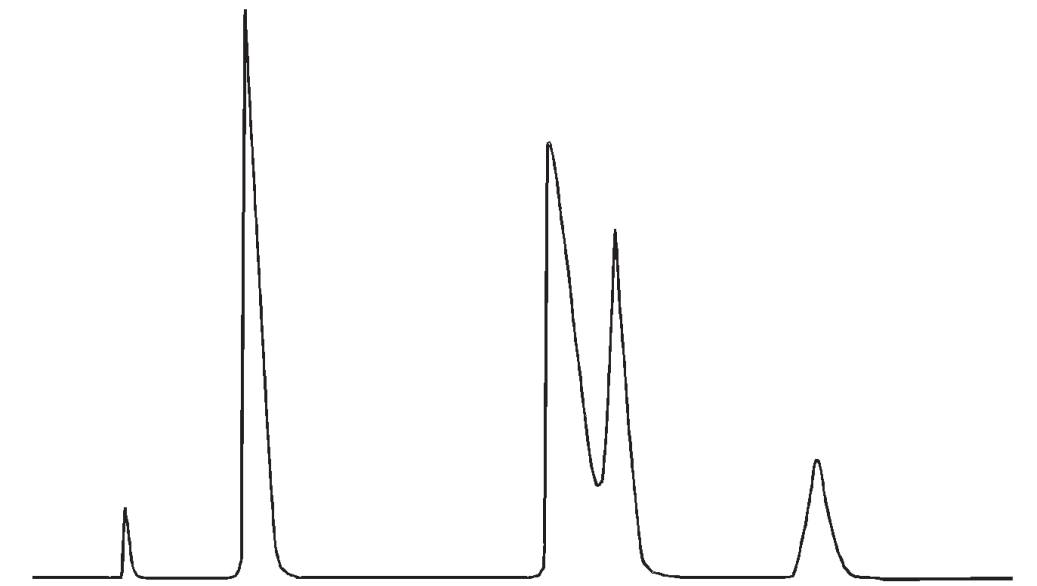

Figure 8-1
Typical Chromatogram on Carbowax

<u>Compound</u>	<u>Boiling Point</u>
<i>n</i> -Heptane	98 °C
Tetrahydrofuran	64 °C
2-Butanone	80 °C
<i>n</i> -Propanol	97 °C

Table 8-1
Components of Sample

- E. Change the **POLARITY SWITCH**. Run the same sample on the other column, DC-200. This time the chromatogram will show four (4) peaks (plus air), but the spacing of the peaks will be different. The four components elute in exactly the reverse order that they did on the Carbowax column — *n*-propanol elutes first, 2-butanone second, etc. Verify this by again running the individual liquids. A typical chromatogram is shown in Figure 8-2.

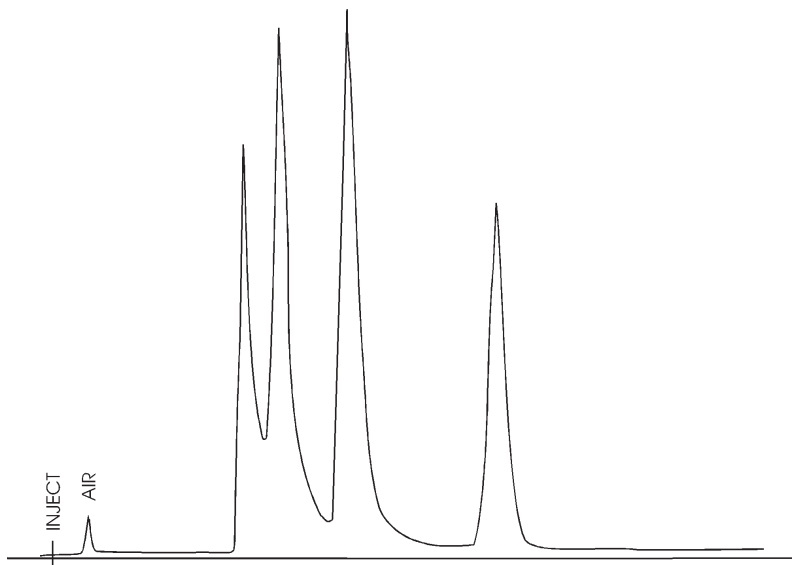

Figure 8-2
Typical Chromatogram on DC-200

- F. Naturally, all mixtures will not have opposite orders of elution on these two columns, but this example should serve to illustrate the large differences that are possible. The main factor which determines the retention volume (time) for a given component on a given column (at a given temperature) is the interaction between it and the liquid phase. The general rule is that polar columns retain polar samples and vice-versa. Note that this is true and in this example where the polar, polyglycol Carbowax retained the alcohol until last, and the non-polar silicone oil DC-200 retained the non-polar paraffin until last.

This partitioning of the sample between liquid and gas phases is much more important than the boiling points of the components. The latter are given in Table 8-1 and you can see that no pattern is followed among this group of compounds. However, samples do elute in order of increasing boiling point if all members of the sample belong to the same homologous series.

- G. In performing a given separation, the choice of the liquid phase is obviously very important. The other important variable is the efficiency of the column as expressed in theoretical plates. The number of theoretical plates in a column, *n*, is one way of comparing the width of the peak with the length of time it was in the column. This is important because peaks get wider the longer they stay in the column. One way of expressing *n* is:

$$n = 16 \left(\frac{\text{retention time}}{\text{peak width}} \right)^2 = 16 \left(\frac{x}{y} \right)^2$$

Figure 8-3 shows how to make these measurements. Calculate n for the last peak in each of your chromatograms, x and y in same units; e.g. inches, centimeters, seconds or minutes.

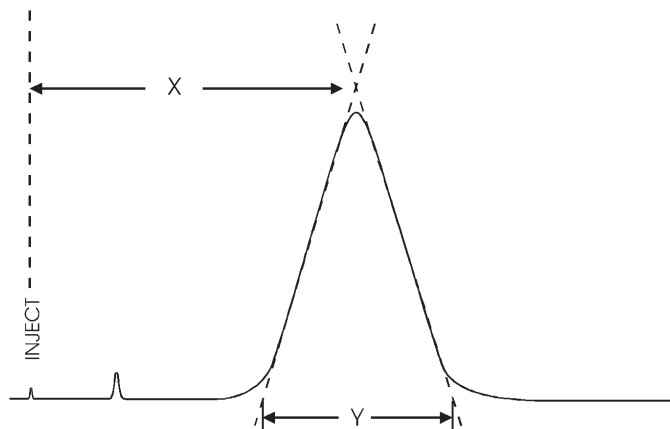

Figure 8-3

8.6 Shutdown Procedure

The following sequence of steps should be followed in the given sequence to insure proper cool-down of your GC and longer life of the detector filaments.

- A. Push the SET and DETECTOR CURRENT Buttons "IN".
- B. Turn the DETECTOR CURRENT CONTROL counterclockwise until the DIGITAL PANEL METER displays between 28 to 40. Then turn the CURRENT SWITCH to "off" position.
- C. Repeat Steps A & B above for the COLUMN, DETECTOR, and INJECTOR.
- D. Let the GC cool down for 30 minutes. For quicker oven cool down, the column oven lid may be lifted and left open.
- E. Let the GC cool for 20 more minutes.



**IF THE INSTRUMENT IS NOT LEFT TO COOL PROPERLY,
THE DETECTOR FILAMENTS MAY BURN OUT (OXIDIZE).**

- F. Elute all samples from the column BEFORE the columns cool down.
- G. Shut ac power OFF.
- H. Turn helium or other carrier gas "OFF".



IT IS MOST IMPORTANT THAT ELECTRICAL POWER BE TURNED OFF BEFORE THE HELIUM IS TURNED OFF. AS LONG AS THE CELL AND FILAMENTS ARE HOT, THE HELIUM SHOULD BE FLOWING THOUGH THE FLOW RATE CAN BE REDUCED TO CONSERVE HELIUM.

Chapter 9 - Maintenance

9.1 The Detector and Elements

A. Limits of Operation

The elements (aka hotwires or filaments) used in the Series 400 GC are GOW-MAC rhenium-tungsten (WX). They may be purchased from GOW-MAC in "quads". A quad consists of four matched and balanced filaments with cable (P/N 13-355-400). WX filaments should be used within the specified limits as shown in Chart 4-1.

9.2 Cell Replacement



BEFORE ATTEMPTING TO REMOVE THE CELL OR FILAMENTS, ALL POWER TO THE INSTRUMENT MUST BE TURNED OFF BY REMOVING THE PLUG FROM THE OUTLET.

- A. Remove the columns using a 9/16" open end wrench.
- B. Remove the two (2) screws located at the **OUTLET PORT** on the left side of the instrument.
- C. Remove the septum nuts (injection port nuts).
- D. Remove all screws from the front panel.
- E. Remove two (2) screws from the back panel.
- F. Remove the insulation to uncover the detector (cell) housing, the detector bracket, and the exit tubes.



INSULATION CONTAINS FIBERGLASS. THE USE OF GLOVES AND FACE PROTECTION IS STRONGLY RECOMMENDED.

- G. Disconnect the **CELL LEADS** from the bottom **TERMINAL STRIP** (refer to the wiring schematic, terminals 3, 4, 5, and 6).



NOTE

Remember that the color code for the connections between the cell leads and the terminal strip are as follows:

BLUE-BLUE; GREEN-GREEN; BLACK-BLACK; RED-RED.

- H. Remove the two (2) screws from the **CELL BRACKET**.
- I. Remove the two (2) upper screws from the **CELL HOUSING**.
- J. **CAREFULLY** remove the **CELL HOUSING**.
- K. Remove the **CELL HOUSING LID** by removing the two (2) uppermost screws.
- L. Remove the **CELL**.

9.3 Filament Replacement

- A. Place cell in vise.
- B. Using a 1/2" box wrench, remove each of the four (4) nuts holding each of the four (4) filaments in place.
- C. Examine the cell for any accumulation of material and general cleanliness.
- D. Clean the cell if necessary before installing new filaments using acetone.



CLEANING SOLVENTS ARE EXTREMELY FLAMMABLE. USE CARE WHEN USING THESE MATERIALS. DO NOT EXPOSE THEM TO OPEN FLAMES OR SMOKING MATERIALS. DISPOSE OF SOLVENTS PROPERLY.

- E. Refer to the **GENERAL SERVICE BULLETIN** (following the mechanical drawings of this manual) for recommendations on installing new filaments.
- F. The new filaments should be installed in the cell, the nuts replaced and tightened, and a leak check made before the cable is threaded back through the hole in the heater plate.

9.4 Columns



When ordering new columns, please specify:

1. **Instrument series & serial number**
 2. **Whether column is for side "A" or "B"**
 3. **Column length and diameter, example: 4' x 1/4"**
 4. **% Liquid phase**
 5. **%Solid support**
 6. **Mesh size**
-

9.5 Changing Columns

- A. Care should be used when changing or removing columns. Damage to adjacent threads can occur if they are hit with a wrench or other object or the nuts may be crossed threaded.
- B. Figure 9-2 shows the injection port for low dead volume utilizing on-column injection. Either 1/4" or 1/8" o.d. columns can be used as shown. All 1/8" o.d. columns are furnished with 1/4" adapters.

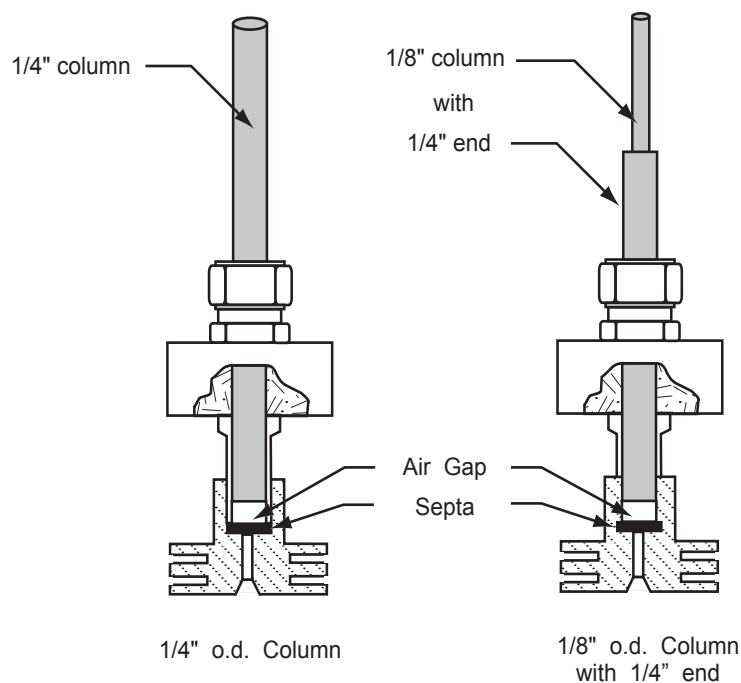

Figure 9-2

9.6 Septums

- A. The septums used in the Series 400 GC are standard 9 mm o.d. and may be obtained directly from GOW-MAC (part no. 180-123S). The **INJECTION PORT NUT** may be easily removed and the septum replaced. The **INJECTION PORT NUT** acts as a heat sink, and should be kept clean and polished.



INJECTION PORTS MAY BE HOT! WEAR APPROPRIATE PROTECTIVE GLOVES.

9.7 Temperature Control

The Series 400 GC can be operated at temperatures ranging from ambient to 400 °C. Operating temperature is maintained at the injection ports, the column oven, and the detector.

Temperature controls on the injection ports, column oven, and detector are independent solid state, proportioning type. Proportioning cycle rate is approximately 2 ½ seconds with a total band width of 5 °C. Temperature readout and "SET" are on a 3 ½ digit digital meter. Selector buttons are used to read the desired temperatures.

9.8 Column Oven Temperature Control

The column oven is heated by a 500 W tubular heater controlled by a proportional control. The solid state control incorporates a platinum RTD (Resistance Temperature Detector) and a 3-1/4 turn set potentiometer. Built into the circuitry is a fail-safe feature which disables the controller's triac output in the event of shorted or open sensor.

The "Temperature Fail Safe" feature has independent shut down at 400 °C for injection ports and detector. The column oven shuts down 30 °C above the column oven set point. The heating units return to safe condition when the temperatures decrease to safe levels. The controller is easily removed for service or replacement.

9.9 Detector Temperature Control

The detector is heated by a 100 W heater mounted in the DETECTOR HOUSING. The temperature control sensor is also located in the housing.

The detector temperature is controlled in the same manner as the column oven.

It is IMPORTANT to remember that the detector is heated by filaments as well as the heaters, and **CANNOT** be operated at ambient temperature. Even with the heaters turned "OFF", the detector will rise in temperature to about 70 °C due to the heat being dissipated by the filaments.

9.10 Injector Temperature Control

The injection ports are heated by 60 W heaters mounted inside the injector block. The temperature control sensor is also located in the block.

The injection port temperature is controlled in the same manner as the column oven.

9.11 Power Supply

A. The power supply consists of a power transformer, rectifier circuit, integrated circuit and external power pass transistor.

1. **Power Transformer:** A step-down transformer is used to reduce the AC voltage to 24 V. The transformer is designed for both 50 and 60 Hz operation. Two transformers are available for proper matching with the AC line voltage, i.e., 115 and 230 V.
2. **Rectifier Circuit:** A full wave type silicon bridge rectifier is used to convert the AC voltage from the secondary of the power transformer to pulsating direct current. A capacitor input filter is used to smooth out the pulsating direct current.

3. **Integrated Circuit:** A solid state, silicon, monolithic integrated circuit regulator is used to regulate the DC output of the power supply. This provides line voltage regulation of less than $\pm 0.25\%$. An external voltage control provides continue adjustment of the output voltage from 3 to 20 DC. This control is marked **CURRENT** on the front panel of the GC.
4. **Power Pass Transistor:** All direct current is passed through the Silicon Power Transformer.

9.12 Technical Assistance and Service

Call our Repair Department at (610) 954-9000 to receive technical assistance, an estimate for repair, as well as a Health and Safety form (see back of this manual or, if it is missing, contact us or visit our website to download the form.) A completed Health & Safety form and purchase order or credit card information are required before we can give an RMA number along with Repair Return Instructions. Instruments or TCDs received without a completed Health & Safety form or RMA will not be permitted into our facility.

Display the RMA number on your shipping label to insure prompt attention upon arrival at GOW-MAC.

GOW-MAC Instrument Co.
Attn: Repair Dept, RMA# _____
277 Brodhead Road
Bethlehem, PA 18017-8600

Please include a contact person, phone number, service required and a P.O. number. We are also able to furnish an estimate prior to repairs if this is required.

Chapter 10 - Replacement Parts

	<u>Description</u>		<u>Part Number</u>
Heaters (115 V)	Column Oven Heater	300 W	124-252
	Cell Oven Heater	100 W	124-181
	Injection Port Heater	60 W	124-152
	*Outlet Port Heater	60 W	124-152
Heaters (230 V)	Column Oven Heater	300 W	124-253
	Cell Oven Heater	100 W	124-182
	Injection Port Heater	60 W	124-153
	*Outlet Port Heater	60 W	124-153
Electronic Modules (115 V)	Constant Current Power Supply		123-191
	Temperature Controller		123-177
	PCB Assembly, Display		123-194
	*Switch, Rotary, Dimmer (Outlet)		120-246
Electronic Modules (230 V)	Constant Current Power Supply		123-191-230
	Temperature Controller		123-177-230
	PCB Assembly, Display		123-194
	*Controller, Solid State (Outlet)		124-202
Mechanical Assemblies	Injection Port Assembly		069-30
	Detector Assembly, complete, standard		069-78-S
	*Detector Assembly, complete, preparative		069-78-P
Electronic Parts & Controls	Potentiometer, 20K (zero)		111-178
	Switch, pressure		120-130
	Switch, DP2T w/ Actuator (Polarity & Current On/Off)		120-168
	Switch, Pushbutton (Outlet Temp Read)		120-205
	115 V Fuse		121-162
	230 V Fuses, (2)		121-177
	Attenuator Board Assembly		123-175
	Recorder Cable, 6'		141-354
	Knob, ring base		127-325
	Knob		127-354
	Knob, locking type		127-386
	Meter, Panel, LED 3 ½ digit digital		128-274
	*Potentiometer, 1M (Outlet)		111-105
	TCD Outlet Temperature Control (69-400-TCD-P Models for Prep GC only)		
Power Entry Module/Switch		129-152-10A	

* Replacement parts for instruments with preparative option

Miscellaneous	Filaments, quad, WX	13-355-400
	Probe, Platinum RTD w/ 37" leads	124-175-T
	Injection Port Nut	176-125
	Metering Valve	180-612
	Binding Post, red	129-172
	Binding Post, black	129-173
	Binding Post, green	129-174
	Foot, rubber	141-452
	Septums, 9 mm (100/pkg)	180-123S
	*Microscale Prep Kit	59-425
	(2 prep columns & GC glassware)	
	*Microscale Prep Glassware	180-350
	Replacement Kit	

* Replacement parts for instruments with preparative option

Chapter 11 - Mechanical Drawings

Thermal Conductivity Detector Assembly	Drawing	B-18751
Flow Diagram (Typical)	Drawing	A-17065
Wiring Schematic (115 V)	Drawing	C-18002
69-400-TCD-P Wiring Schematic (115 V)	Drawing	C-18002-1

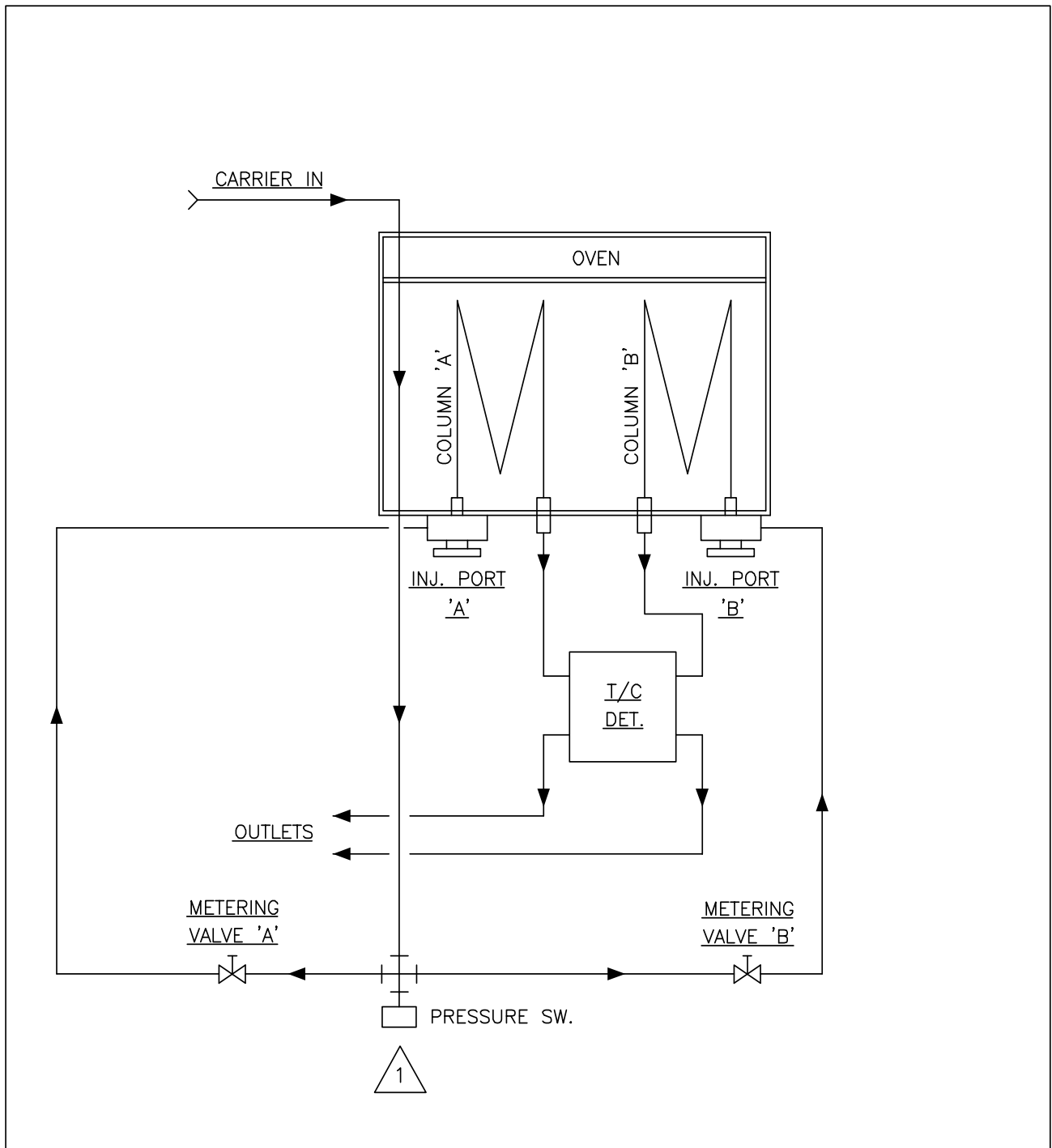

FILE: A17065R1.DWG					DWN. SML	NAME	FLOW DIAGRAM 69-400-TCD
					DATE 8/2/96		
					CHK.	MATERIAL	
					SCALE N.T.S.	FINISH	
					TOL. UNLESS NOTED .X ±.04 .XX ±.02 .XXX ±.010 HOLES ±.003 ANGULAR ± 1°	DO NOT SCALE DWG.	 GOW-MAC [®] INSTRUMENT CO. <small>277 BRODHEAD ROAD BETHLEHEM, PA 18017-8600</small>
	1	10/19/23	ADDED PRESSURE SWITCH	SML		REV. NO. 1	
NO	DATE	CHANGE	BY	ECO			A-17065

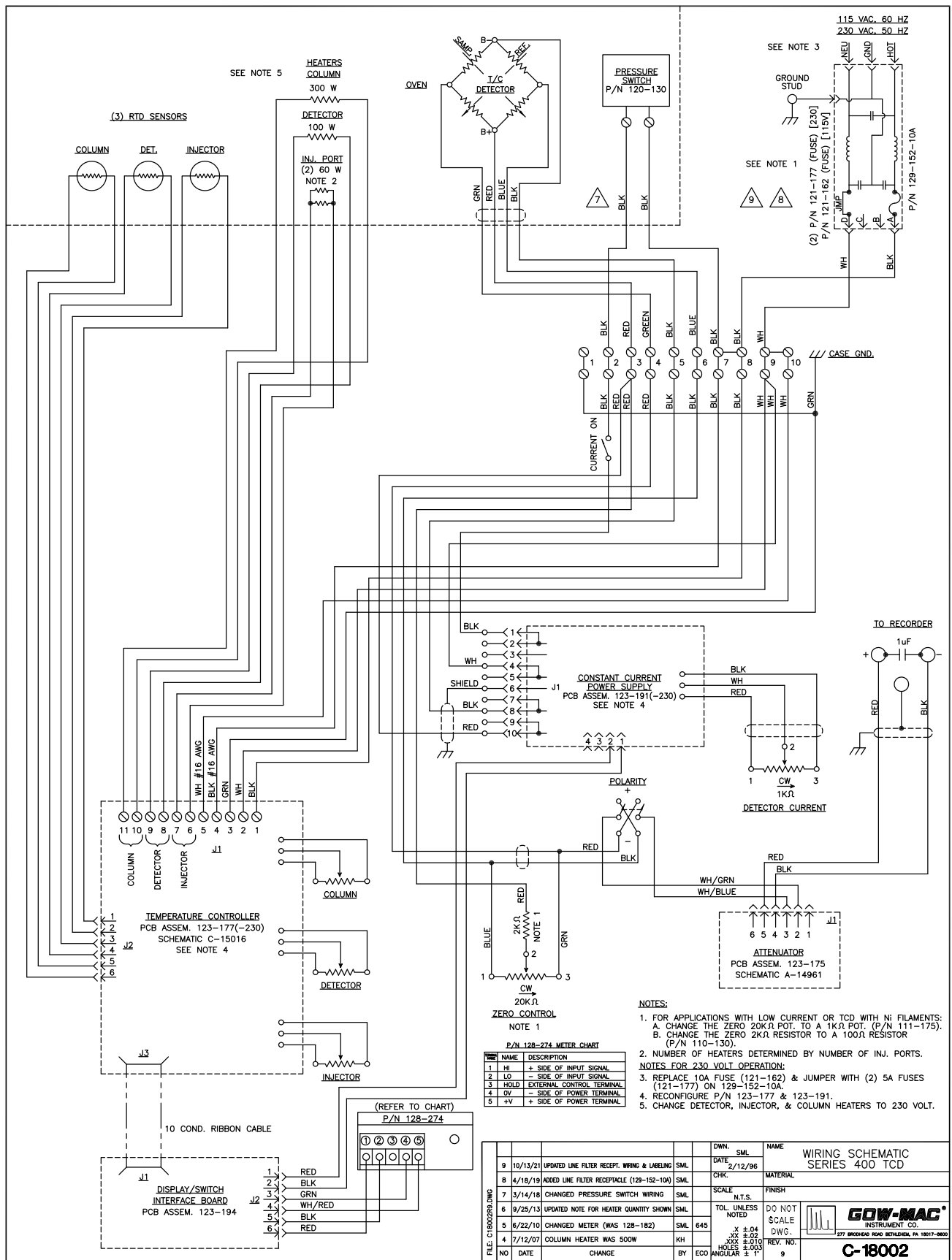

Health and Safety Declaration for the Return of GOW-MAC Instrument Co. Equipment

In order to protect our employees from exposure to various hazards, the following statements and/or questions **MUST** be answered by you. Fill out this document in its entirety and either fax or e-mail it to GOW-MAC Instrument Co., Attn: Repair Dept, **BEFORE** returning the product.

The instrument/part being returned **will not** be accepted into GOW-MAC's facility until we receive this completed document, along with a **PO or Credit Card**. Once approved for return by our Chemical Safety Officer, a **Return Materials Authorization (RMA) number** and shipping instructions will be issued. *All applicable regulations should be followed when returning instrumentation, and/or parts.*

Customer to Record the Following:

Model # / Part # _____

Serial #: _____

Service Technician spoken to: _____

Today's Date: _____

IF THIS FORM IS NOT APPROVED BY OUR CHEMICAL SAFETY OFFICER, THE INSTRUMENT/PART WILL NOT BE PERMITTED INTO OUR FACILITY FOR SERVICING!

- A) Brief explanation of issue: _____
- B) Briefly list the application(s) for which the instrument/part was used, as well as any and all chemicals, gases, and/or materials analyzed and their concentrations. **(Must be filled in):** _____
- C) Is there the possibility of internal or external contamination on or in this instrument/part?
 Yes – see below No – proceed to D.

Please check the appropriate box.

- Chemicals or Substances That Are Hazardous to Health
- Blood, Body Fluids, (e.g. Urine, Secretions), Pathological Specimens
- Regulated Medical Wastes
- Infectious Substances or other Bio-Agents (e.g. Protein, Enzymes, Antibodies)
- Radioactive Isotopes used in the area. Detail type (ECD, Isotopic Labels, etc) and Activity in Micro Curies
- Biodegradable Material That Could Become Hazardous
- Other Hazards _____

If any of the above boxes are checked the following statements and/or questions must be answered.

1. Specifically describe where (on or in) the instrument/part there could be any residual contamination (for example: blood spill on the surface). _____
2. Provide details of these hazards. Include names, Material Safety Data Sheets (MSDS), and concentration of contaminants, where possible. _____
3. Describe the method of decontamination used. Attach Procedure. _____

- D) I declare that the above information is true and complete to the best of my knowledge. I acknowledge that any inconsistencies between the condition of the instrument and the statements made on this form will delay the repair process.

Authorized signature _____ Date: _____

Name (Printed) _____ Phone number: _____
 Company name: _____ Fax number: _____

Shipping address: _____
 City: _____ State/Country: _____ Zip: _____
 E-mail address: _____

BEFORE item can be shipped, fax completed form to: (610) 954-0599 or e-mail it to: repairs@gow-mac.com

For GOW-MAC Use Only:	Signed: _____	Date ____/____/____
<input type="checkbox"/> Passed Safety Inspection. OK to proceed to Repair Dept.	Chemical Safety Officer	Comments: () None
<input type="checkbox"/> Failed safety inspection. DO NOT proceed to Repair Dept.	RMA No: _____	() On Back >>>>



REP-005
 Health-Safety Declaration Doc – ONLINE
 Rev.7 1/28/2022, kj

